

## Style 441

### Stainless Steel Vic-Flange® Adapter 2 - 6" (60,3 - 168,3 mm)

#### IMPORTANT INFORMATION



**⚠ WARNING**

- Read and understand all installation instructions before attempting to install any Victaulic piping products.
- Wear hardhat, safety glasses, and foot protection.

Failure to follow these instructions could result in serious personal injury, property damage, and/or product damage.

**⚠ WARNING**

- Depressurize and drain piping systems before attempting to install, remove, or adjust any Victaulic piping products.

Failure to follow these instructions could result in serious personal injury and/or property damage.

The following instructions are a guide for the proper installation of Victaulic Style 441 Stainless Steel Vic-Flange Adapters. Proper installation requires pipe that is prepared and grooved in accordance with the latest Victaulic specifications.

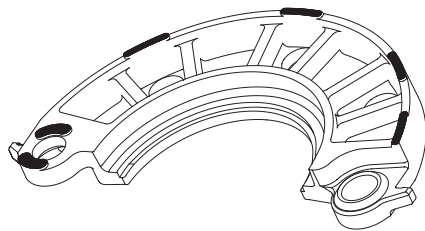

- The Style 441 is designed for use with Class 150 raised-face flanges, in accordance with ANSI B16.5. When a Style 441 is used with a flat-faced flange, the raised projections on the outside edge and around the mating holes of the flange adapter must be ground flush to the body. The shaded areas on the sketch to the left identify the projections that need to be ground flush on both segments.
- The Style 441 cannot be used, unless it mounts flush to the mating flange; therefore, flange washers, or anything else that prevents flush mounting, cannot be used.
- The Style 441 must not be used as anchor points for tie rods across non-restrained joints.
- The Style 441 must not be used against rubber coated surfaces or with wafer or lug-type valves, or when the flange adapter does not mount flush with the mating flange.
- Because of the outside flange dimension, the Style 441 must not be used 90° to one another on a standard fitting.

**ALWAYS VERIFY THAT THE GASKET IS SUITABLE FOR THE INTENDED SERVICE.** Refer to publication 05.01 for complete information.

#### PIPE AND MATING FACE PREPARATION

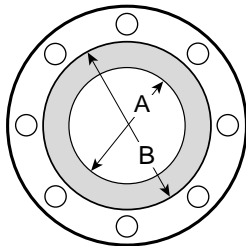

Figure 1

PIPE SIZE		Sealing Surface inches/mm	
Nominal Diameter in/mm	Actual Out. Dia. in/mm	"A" Max.	"B" Max.
2 50	2,375 60,3	2,40 61	3,40 86
2½ 65	2,875 73,0	2,90 74	3,90 99
3 80	3,500 88,9	3,50 89	4,50 114
4 100	4,500 114,3	4,50 114	5,50 140
6 150	6,625 168,3	6,60 168	7,80 198

**1.** The outside surface of the pipe (from the pipe end to the groove) must be smooth and free from indentations, projections, and roll marks to provide a leak-tight seal for the gasket. All rust, loose scale, oil, grease, and dirt must be removed.

**2.** The gray area of the mating face (Figure 1) must be free from gouges, undulations, or deformities of any type for proper sealing.

VICTAULIC® IS AN ISO 9001 CERTIFIED COMPANY

<b>Victaulic Company of America</b> Phone: 1-800-PICK-VIC (1-800-742-5842) Fax: 610-250-8817 e-mail: pickvic@victaulic.com	<b>Victaulic Company of Canada</b> Phone: 416-675-5575 Fax: 416-675-5565 e-mail: viccanada@victaulic.com	<b>Victaulic Europe</b> Phone: 32-9-381-1500 Fax: 32-9-380-4438 e-mail: viceuro@victaulic.be	<b>Victaulic America Latina</b> Phone: 610-559-3300 Fax: 610-559-3608 e-mail: vical@victaulic.com	<b>Victaulic Asia Pacific</b> Phone: 65-6235-3035 Fax: 65-6235-0535 e-mail: vicap@victaulic.com
---	---	---	--	--

# Installation Instructions



**1.** Insert a standard bolt through a mating hole to act as a hinge, as shown above.

## BOLT REQUIREMENTS

PIPE SIZE		Number of Bolts Required*	Bolt Size inches
Nominal Diameter in/mm	Actual Out. Dia. in/mm		
2 50	2.375 60,3	4	5/8 X 2 3/4
2 1/2 65	2.875 73,0	4	5/8 X 3
3 80	3.500 88,9	4	5/8 X 3
4 100	4.500 114,3	8	5/8 X 3
6 150	6.625 168,3	8	3/4 X 3 1/2

\*Bolts are not supplied by Victaulic. When using stainless steel bolts/nuts, consideration should be given to using an anti-seize lubricant on the threads.



**2.** Check the gasket supplied to make sure it is suitable for the intended service. The color code identifies the gasket grade. Apply a thin coat of Victaulic lubricant or silicone lubricant to the gasket lips and exterior.



**3.** Install the gasket onto the pipe end. Make sure the gasket is properly positioned, as shown in Figure 2 below. **NOTE:** The markings on the outside of the gasket must face the Style 441 flange adapter.

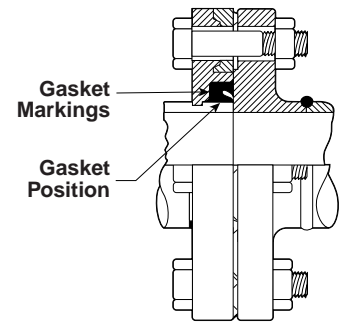

Figure 2



**4.** Place the hinged flange around the grooved pipe end. Make sure the key section of the flange adapter engages in the pipe groove.



**5.** Closure lugs are provided to ease installation. Clamp both lugs with a wrench or pliers, and pull the two segments together until the bolt holes align.



**6.** When the bolt holes are aligned, insert a standard bolt through the other mating hole.



**7.** Make sure the gasket is still seated properly in the flange adapter.



**8.** Join the mating flange with the Vic-Flange by aligning the two bolts with the mating flange's holes.



**9.** Install a nut onto the two bolts. Tighten until the nuts are finger-tight.



**10.** Install the remaining standard bolts through the Vic-Flange and the mating flange. Install all nuts until they are finger-tight.



**11.** Tighten all nuts evenly in a crossing pattern, as with a regular flange assembly. Continue to tighten all nuts until the standard, flange-joint torque recommendation is achieved.