







Vic®-300 MasterSeal™ Butterfly Valves

SERIES 761



WARNING

WARNING

- Read and understand all instructions before attempting to install, remove, adjust, or perform maintenance on any Victaulic piping products.
- Depressurize and drain piping systems before attempting to install, remove, adjust, or perform maintenance on any Victaulic piping products.
- Wear safety glasses, hardhat, foot protection, and hearing protection.

Failure to follow instructions and warnings could cause system failure, resulting in serious personal injury and/or property damage.

Vic[®]-300 MasterSeal[™] Butterfly Valves

SERIES 761

TABLE OF CONTENTS

Hazard Identification 1
 Vic-300 MasterSeal Butterfly Valve Components 2
 Installation Information. 3
 Vic-Flange Adapter Notes 3
 System-Related Considerations 3

SECTION I - VIC-300 MASTERSEAL BUTTERFLY VALVE MAINTENANCE

Stem Seal Replacement for 2 - 12-inch/60.3 - 323.9-mm Valves. 6

SECTION II - VIC-300 MASTERSEAL BUTTERFLY VALVE MEMORY STOP FEATURE AND KIT INSTALLATION INSTRUCTIONS

Setting the Memory Stop Feature on 2 - 6-inch/60.3 - 168.3-mm Valves with 10-Position Handles 10
 Using the Infinitely Variable Feature on 2 - 6-inch/60.3 - 168.3-mm Valves with 10-Position Handles 10
 Memory Stop Feature on 8-inch/219.1-mm Valves with Lever Lock Handles 11
 "A" - Setting the Memory Stop Feature on 8-inch/219.1-mm Valves with Lever Lock Handles 11
 "B" - Setting the Memory Stop Feature on 8-inch/219.1-mm Valves with Lever Lock Handles 13
 10-Position Handle Removal for 2 - 6-inch/60.3 - 168.3-mm Valves 14
 Lever Lock Handle Removal for 8-inch/219.1-mm Valves. 16
 Tamper-Resistant Handle Kit Installation for 2 - 6-inch/60.3 - 168.3-mm Valves with 10-Position Handles 18
 Tamper-Resistant Handle Kit Installation for 8-inch/219.1-mm Valves with Lever Lock Handles 21
 Telescopic Handle Kit Installation for 10 - 12-inch/273.0 - 323.9-mm Valves 23
 Gear Operator Installation for 2 - 12-inch/60.3 - 323.9-mm Valves 27
 Adjusting and Setting the Closed Travel Limit Stops of the Gear Operator 29
 Adjusting and Setting the Open Travel Limit Stops of the Gear Operator 30
 Memory Stop Kit Installation for 2 - 12-inch/60.3 - 323.9-mm Gear-Operated Valves 31
 Thermal Barrier Kit Installation for 2 - 12-inch/60.3 - 323.9-mm Valves 33
 Insulation Extension Kit for 2 - 8-inch/60.3 - 219.1-mm Gear-Operated Valves 34
 Insulation Extension Kit Installation for 2 - 8-inch/60.3 - 219.1-mm Gear-Operated Valves 35
 Insulation Extension Kit for 2 - 6-inch/60.3 - 168.3-mm Valves with 10-Position Handles 36
 Insulation Extension Kit Installation for 2 - 6-inch/60.3 - 168.3-mm Valves with 10-Position Handles 37
 Insulation Extension Kit for 8-inch/219.1-mm Valves with Lever Lock Handles 38
 Insulation Extension Kit Installation for 8-inch/219.1-mm Valves with Lever Lock Handles 39

HAZARD IDENTIFICATION



Definitions for identifying the various hazard levels are provided below. When you see this symbol, be alert to the possibility of personal injury. Carefully read and fully understand the message that follows.

⚠ DANGER

- The use of the word "DANGER" identifies an immediate hazard with a likelihood of death or serious personal injury if instructions, including recommended precautions, are not followed.

⚠ WARNING

- The use of the word "WARNING" identifies the presence of hazards or unsafe practices that could result in death or serious personal injury if instructions, including recommended precautions, are not followed.

⚠ CAUTION

- The use of the word "CAUTION" identifies possible hazards or unsafe practices that could result in personal injury and product or property damage if instructions, including recommended precautions, are not followed.

NOTICE

- The use of the word "NOTICE" identifies special instructions that are important but not related to hazards.

Vic[®]-300 MasterSeal[™] Butterfly Valves

SERIES 761

VIC[®]-300 MASTERSEAL[™] BUTTERFLY VALVE COMPONENTS

NOTICE

- For clarification purposes, drawings and/or pictures in this manual may be enlarged and not to scale.
- This manual contains trademarks, copyrights, and product with patented features that are the exclusive property of Victaulic.

Bill of Materials

Item	Qty.	Description	Item	Qty.	Description
1	1	Valve Body Mounting Flange	8	1	Upper Bearing
2	1	End Face	9	1	Lower Bearing
3	1	Disc	10	1	O-Ring
4	1	Seat	11	1	Seal Cartridge
5	1	O-Ring	12	1	Retaining Ring
6	1	Stem	13	2	O-Ring
7	1	Stem Nut	14	2	O-Ring

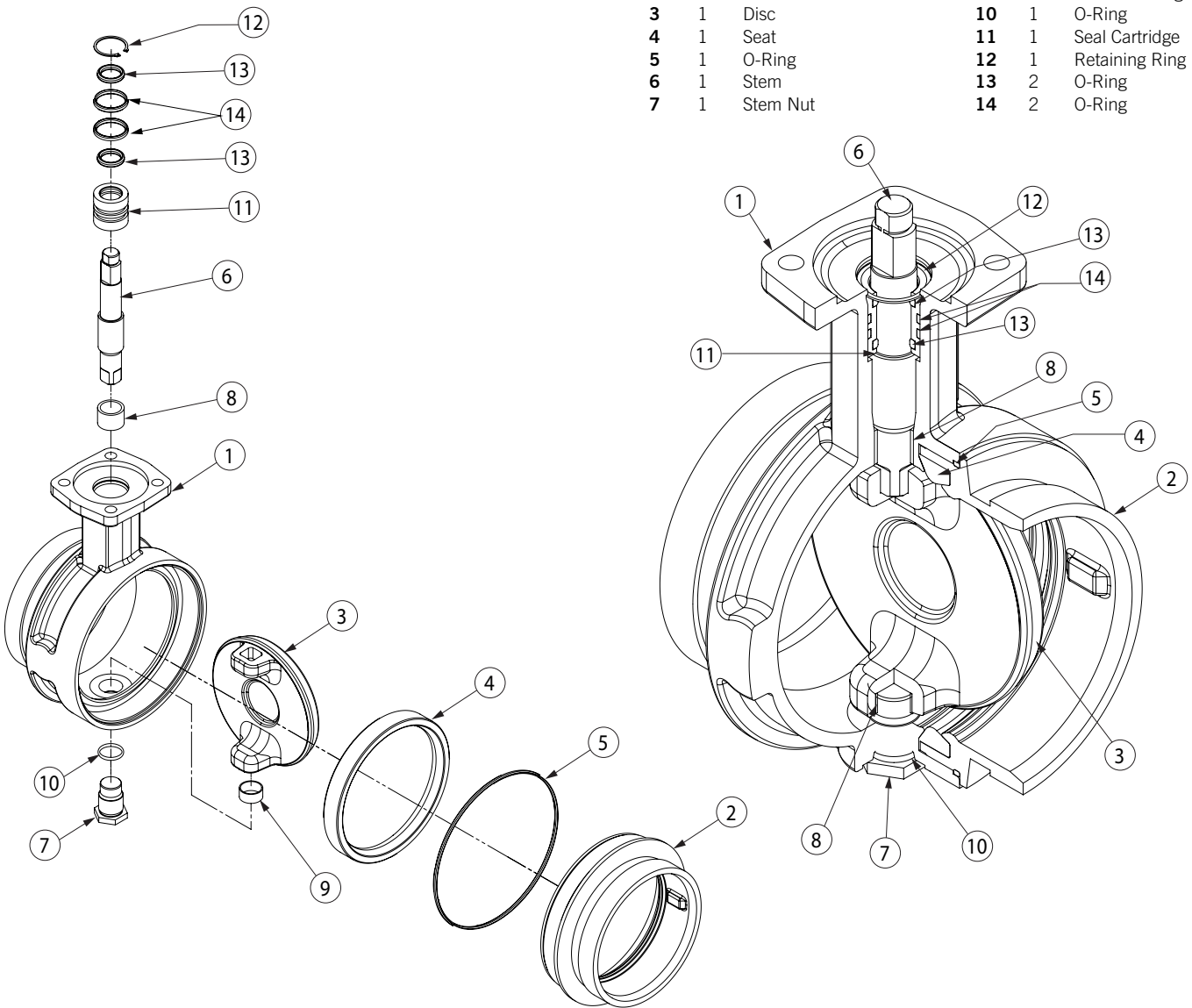

Vic[®]-300 MasterSeal[™] Butterfly Valves

SERIES 761



INSTALLATION INFORMATION

For installing a Vic-300 MasterSeal Butterfly Valve into a piping system, follow the instructions supplied with the coupling or flange adapter. Refer to the notes below for applications/limitations.



DO NOT INSTALL VIC-300 MASTERSEAL BUTTERFLY VALVES INTO THE SYSTEM WITH THE DISC IN THE FULLY OPEN POSITION.

- When using Vic-300 MasterSeal Butterfly Valves for throttling service, Victaulic recommends positioning the disc no less than 30 degrees open. For best results, the disc should be between 30 and 70 degrees open. High pipeline velocities and/or throttling with the disc less than 30 degrees open may result in noise, vibration, cavitation, severe line erosion, and/or loss of control. For details regarding throttling services, contact Victaulic.
- Victaulic recommends limiting the flow velocities for water service to 20 feet/second (6.1 meters/second). When higher flow velocities are necessary, contact Victaulic. When dealing with flow media other than water, contact Victaulic.
- Lubricated nitrile "T" seat seals are recommended for dry or lubricated gas services.
- When directly connecting an end cap to a Vic-300 MasterSeal Butterfly Valve, use only an end cap with a tapped hole for attaching a pressure relief device. If the valve is opened then closed unknowingly while the end cap is attached, the space between the disc and end cap will be filled and pressurized. A sudden release of energy can occur if the end cap is removed while the space behind it is pressurized. **PRESSURE MUST BE VENTED THROUGH THE TAP BEFORE ATTEMPTING TO REMOVE THE CAP.**

 DANGER	
	<ul style="list-style-type: none"> • When directly connecting an end cap to a butterfly valve, use only an end cap with a tapped hole for attaching a pressure relief device. • Pressure must be vented through the tap before attempting to remove the cap. <p>Failure to follow these instructions could result in death or serious personal injury.</p>

Vic-300 MasterSeal Butterfly Valves are designed with grooved ends for use with grooved pipe couplings. If flange connections are required, refer to the notes on this page regarding Vic-Flange Adapter restrictions.

VIC-FLANGE ADAPTER NOTES

- Style 741 Vic-Flange Adapters can be used on all sizes of Vic-300 MasterSeal Butterfly Valves.
- Vic-300 MasterSeal Butterfly Valves cannot be directly connected to flanged components with Style 743 Vic-Flange Adapters. A No. 46 ANSI 300 groove-by-flange adapter is required for this application.

SYSTEM-RELATED CONSIDERATIONS

- The Vic-300 MasterSeal Butterfly Valve and connecting piping must be supported properly to prevent the joints from being subjected to bending loads, shear loads, or any other external loads.
- The maximum allowable corrosion allowance is 0.8inch/2mm.
- Welding to the valve and couplings is not permitted.

Vic[®]-300 MasterSeal[™] Butterfly Valves

SERIES 761

SECTION I - VIC[®]-300 MASTERSEAL[™] BUTTERFLY VALVE MAINTENANCE



10-POSITION HANDLE WITH MEMORY STOP
2 - 6-INCH/60.3 - 168.3-MM SIZES



LEVER LOCK HANDLE AND MEMORY STOP
8-INCH/219.1-MM SIZE



VALVE WITH LEVER LOCK HANDLE AND MEMORY STOP
10 - 12-INCH/273.3 - 323.9-MM SIZES



VALVE WITH GEAR OPERATOR
2 - 12-INCH/60.3 - 323.9-MM SIZES

Vic®-300 MasterSeal™ Butterfly Valves

SERIES 761

STEM SEAL REPLACEMENT FOR 2 – 12-INCH/60.3 – 323.9-MM VALVES

⚠ WARNING



- Read and understand all instructions before attempting to replace the stem seals.
- Failure to follow all instructions could result in serious personal injury and/or property damage.

⚠ WARNING



- **THE PUMP MUST BE SHUT OFF** to prevent flow from passing through the valve during the following procedures.

Failure to follow this instruction could cause product failure, resulting in serious personal injury and/or property damage.

NOTICE

- **THE STEM SEAL REPLACEMENT PROCEDURE SHOULD BE COMPLETED ONLY IF LEAKAGE IS OCCURRING FROM THE STEM.**
- Make sure the correct stem seal kit was ordered by verifying the o-ring material.
- O-rings for all valve sizes (12 total) are included with the kit. However, only four o-rings are required to repair one valve. Make sure the correct size o-rings are used for the stem seal replacement procedure. Discard any unused o-rings.

1. Removal of the handle assembly or gear operator can be performed without removing the valve from the piping system. **THE PUMP MUST BE SHUT OFF** to prevent flow from passing through the valve during removal of the handle assembly or gear operator.
2. **To remove the handle assembly:** Refer to the appropriate handle removal section in this manual.
3. **To remove the gear operator:** Note the current orientation of the gear operator before proceeding with the following steps. **AS A REFERENCE FOR GEAR OPERATOR RE-INSTALLATION:** Place a mark on the gear operator, the stem, and the valve body mounting flange with a permanent marker or paint pen.
 - 3a. Place the valve disc in the **OPEN** position by turning the handwheel of the gear operator until the pointer is pointing toward the **OPEN** position.
 - 3b. Remove the four existing hex-head screws and lock washers that attach the gear operator to the valve body mounting flange. **NOTE:** These hex-head screws and lock washers are required for re-installation.
 - 3c. Pull straight upward to remove the gear operator and existing drive bushing from the valve body mounting flange. These items are required for re-installation. **DO NOT REMOVE OR ROTATE THE STEM.**
 - 3d. Remove any debris from the valve body mounting flange.



4. Using retaining-ring pliers or a similar device, remove the retaining ring from around the stem assembly, as shown above. If the retaining ring is bent from its original shape, replace it with a new, Victaulic-supplied retaining ring.



5. Remove the stem assembly from the disc/valve body. Be careful not to damage the flats of the drive hub during removal.



6. Remove the seal cartridge from the stem.

Vic[®]-300 MasterSeal[™] Butterfly Valves

SERIES 761



7. Using an o-ring pick or a similar device, remove the two internal and two external o-rings from the seal cartridge.
8. Clean the stem and the interior and exterior surfaces of the seal cartridge. Check the surfaces of the stem and seal cartridge for burrs and sharp edges. File any burrs and sharp edges to prevent o-rings from being cut during re-assembly.
9. Lubricate the seal cartridge and o-rings with Vic-Lube[™] or another compatible material, such as silicone.

10. Install two new o-rings into the seal cartridge, as shown above.

11. Install two new o-rings onto the seal cartridge, as shown above.



12. Insert the stem into the seal cartridge.

⚠ CAUTION

- Use a compatible lubricant to prevent the o-rings from pinching/tearing during installation.

Failure to follow this instruction could result in valve leakage through the stem.

Vic[®]-300 MasterSeal[™] Butterfly Valves

SERIES 761



13. Insert the stem assembly into the valve body/disc. Make sure the rectangular end of the disc aligns with the stem. **NOTE:** The seal cartridge must seat fully in the valve body.



14. Using retaining-ring pliers or a similar device, install the retaining ring over the stem assembly. Make sure the retaining ring fully seats in the recess in the valve body.
15. Re-install the handle assembly or gear operator onto the valve.
16. Operate the valve through a full-open and full-closed cycle to verify proper operation.
17. Place the system back into service.

Vic[®]-300 MasterSeal[™] Butterfly Valves

SERIES 761

SECTION II - VIC[®]-300 MASTERSEAL[™] BUTTERFLY VALVE MEMORY STOP FEATURE AND KIT INSTALLATION INSTRUCTIONS



10-POSITION HANDLE WITH MEMORY STOP
2 - 6-INCH/60.3 - 168.3-MM SIZES



LEVER LOCK HANDLE AND MEMORY STOP
8-INCH/219.1-MM SIZE



VALVE WITH LEVER LOCK HANDLE AND MEMORY STOP
10 - 12-INCH/273.3 - 323.9-MM SIZES



VALVE WITH GEAR OPERATOR
2 - 12-INCH/60.3 - 323.9-MM SIZES

Vic®-300 MasterSeal™ Butterfly Valves

SERIES 761

SETTING THE MEMORY STOP FEATURE ON 2 – 6-INCH/60.3 – 168.3-MM VALVES WITH 10-POSITION HANDLES

- Using the handle, place the valve disc in the desired “open” position.



- Loosen the memory stop nut, as shown above.



- Move the memory stop hardware to make contact with the side of the 10-Position Handle, as shown above. Re-tighten the memory stop nut to maintain the desired “open” location.

USING THE INFINITELY VARIABLE FEATURE ON 2 – 6-INCH/60.3 – 168.3-MM VALVES WITH 10-POSITION HANDLES

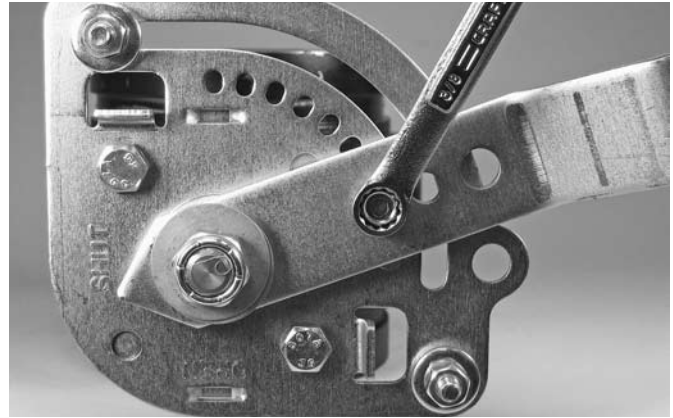

- Remove the detent screw.

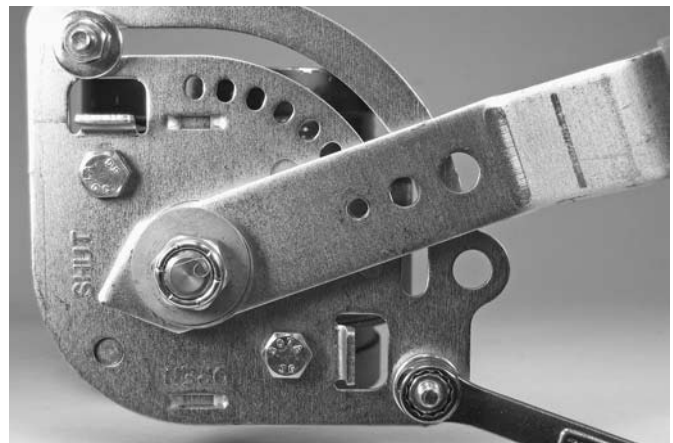

- Remove the hex nut, lock washer, flat washer, and bolt from the plate, as shown above.

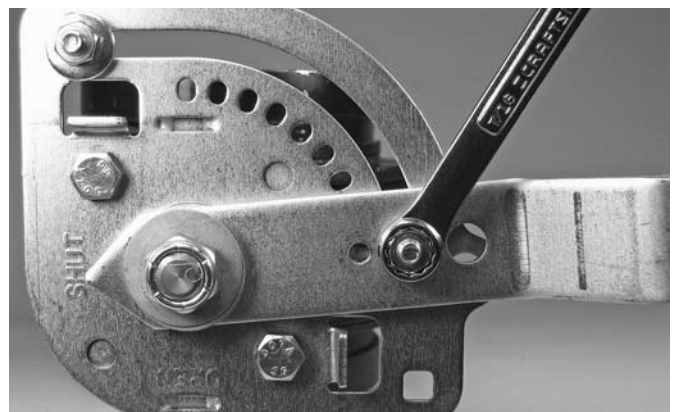

- Install the hardware, removed in step 2, into the center hole in the handle, as shown above.
- To use the memory stop feature with the infinitely variable handle option, refer to the instructions on this page for setting the memory stop.

Vic®-300 MasterSeal™ Butterfly Valves

SERIES 761

MEMORY STOP FEATURE ON 8-INCH/219.1-MM VALVES WITH LEVER LOCK HANDLES

Determine the Lever Lock Handle design that is installed currently on the valve.

If the Lever Lock Handle looks like the graphic below, follow the instructions designated as “A” on this page.

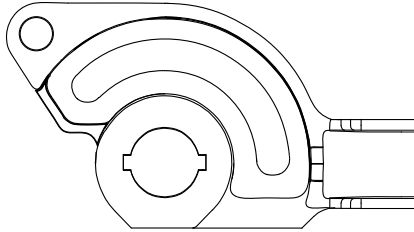

If the Lever Lock Handle looks like the graphic below, follow the instructions designated as “B” on page 13.

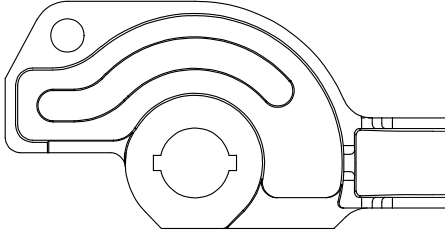

“A” – SETTING THE MEMORY STOP FEATURE ON 8-INCH/219.1-MM VALVES WITH LEVER LOCK HANDLES

⚠ WARNING	
	<ul style="list-style-type: none"> Read and understand all instructions before attempting to remove the Lever Lock Handle assembly. <p>Failure to follow all instructions could result in serious personal injury and/or property damage.</p>

⚠ WARNING	
	<ul style="list-style-type: none"> THE PUMP MUST BE SHUT OFF to prevent flow from passing through the valve during the following procedures. <p>Failure to follow this instruction could cause product failure, resulting in serious personal injury and/or property damage.</p>

Removal of the Lever Lock Handle can be performed without removing the valve from the piping system. **THE PUMP MUST BE SHUT OFF** to prevent flow from passing through the valve during removal of the Lever Lock Handle.



1. Remove the hex nut, lock washer, and flat washer from the hex-head screw, as shown above.



2. Loosen the set screw on the side of the handle, as shown above.
- 2a. Note the current orientation of the Lever Lock Handle. The handle must be re-installed in the same orientation in later steps. Remove the Lever Lock Handle assembly from the plate.

NOTICE
<ul style="list-style-type: none"> The stem contains a key that is essential for re-installation of the handle. Use care to prevent misplacement of this key.



3. Loosen the hex nut of the memory stop hardware, as shown above.

Vic®-300 MasterSeal™ Butterfly Valves

SERIES 761



4. Move the memory stop hardware to the opposite end of the slot, as shown above. Tighten the hex nut to prevent the hardware from moving during re-installation of the Lever Lock Handle.



5. Re-install the Lever Lock Handle in the same orientation, as noted in step 3 on the previous page.



6. Re-install the flat washer, lock washer, and hex nut onto the hex-head screw, as shown above. Tighten the hex nut until the lock washer is compressed.



7. Tighten the set screw on the side of the handle, as shown above.

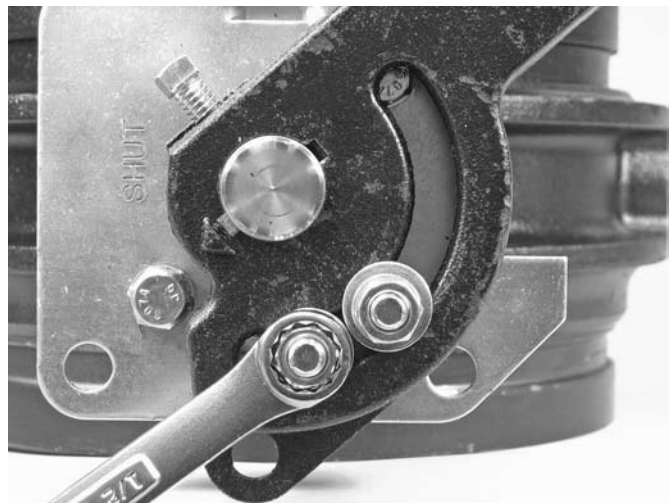

8. Using the handle, place the valve disc in the desired "open" location.
- 8a. Loosen the memory stop nut, as shown above, and move the memory stop hardware to make contact with the stationary handle/plate mounting hardware, as shown above.
- 8b. Tighten the memory stop nut to maintain the desired "open" location.

Vic[®]-300 MasterSeal[™] Butterfly Valves

SERIES 761

“B” – SETTING THE MEMORY STOP FEATURE ON 8-INCH/219.1-MM VALVES WITH LEVER LOCK HANDLES



1. Using the handle, place the valve disc in the desired “open” position.



2. Loosen the memory stop nut, as shown above.



3. Move the memory stop hardware to make contact with the stationary handle/plate mounting hardware, as shown above.
- 3a. Tighten the memory stop nut to maintain the desired “open” location.

Vic®-300 MasterSeal™ Butterfly Valves

SERIES 761

10-POSITION HANDLE REMOVAL FOR 2 – 6-INCH/60.3 – 168.3-MM VALVES

WARNING



- Read and understand all instructions before attempting to remove the 10-Position Handle assembly.

Failure to follow all instructions could result in serious personal injury and/or property damage.

WARNING



- THE PUMP MUST BE SHUT OFF to prevent flow from passing through the valve during the following procedures.

Failure to follow this instruction could cause product failure, resulting in serious personal injury and/or property damage.

Removal of the 10-Position Handle can be performed without removing the valve from the piping system. **THE PUMP MUST BE SHUT OFF** to prevent flow from passing through the valve during removal of the 10-Position Handle.

10-POSITION HANDLE PARTS LIST

Item No.	Qty.	Description
1	1	Handle
2	1	Plate
3	2	Hex Nut with Captive-Toothed Lock Washer (5/16 – 18 UNC)
4	2	Round-Head, Square-Neck Bolt (1/4 – 20 UNC x 3/4-inch Long)
5	4	Spring Washer
6	1	Hex Lock Nut
7	2	Hex Head Screw (5/16 – 18 UNC x 1-inch Long)
8	1	Flat Washer
9	2	Lock Washer (1/4 inch)
10	2	Hex Nut (1/4 – 20 UNC)
11	1	Detent Screw
12	2	Memory Stop Washer

10-POSITION HANDLE ASSEMBLY DRAWING

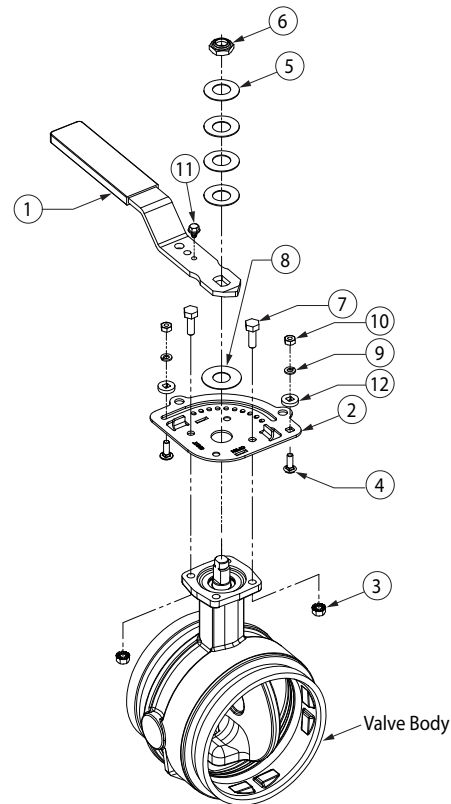

Exaggerated for Clarity

DETAIL OF SPRING WASHERS AND LOCK NUT

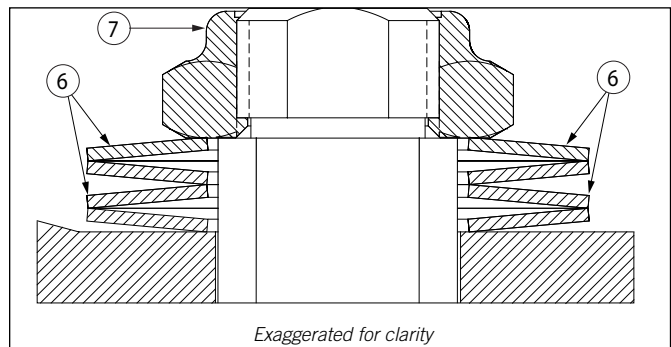

Exaggerated for clarity

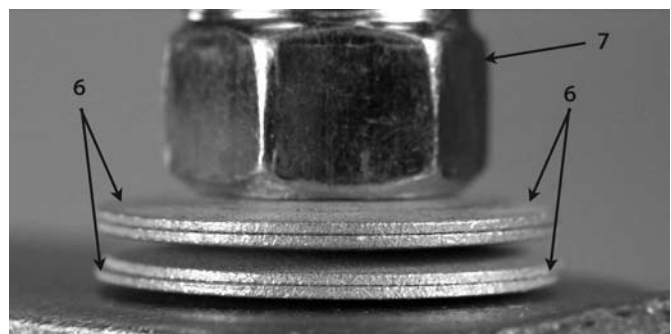

Vic[®]-300 MasterSeal[™] Butterfly Valves

SERIES 761

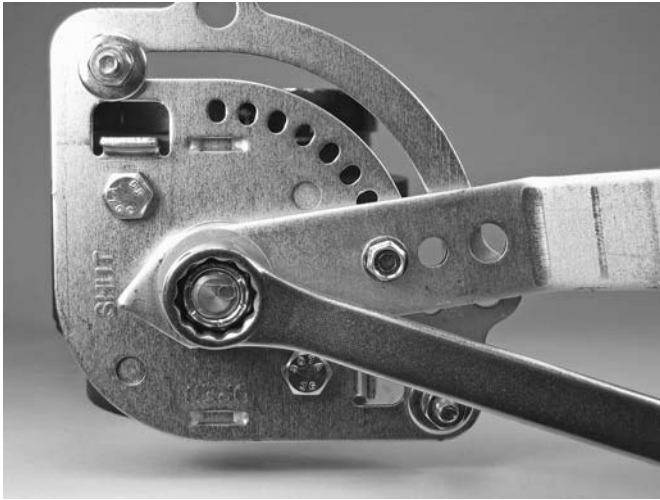

1. Remove the hex lock nut (Item 6) from the threaded portion of the drive hub.
2. Remove the spring washers (Item 5), handle (Item 1), and flat washer (Item 8) from the stem assembly.

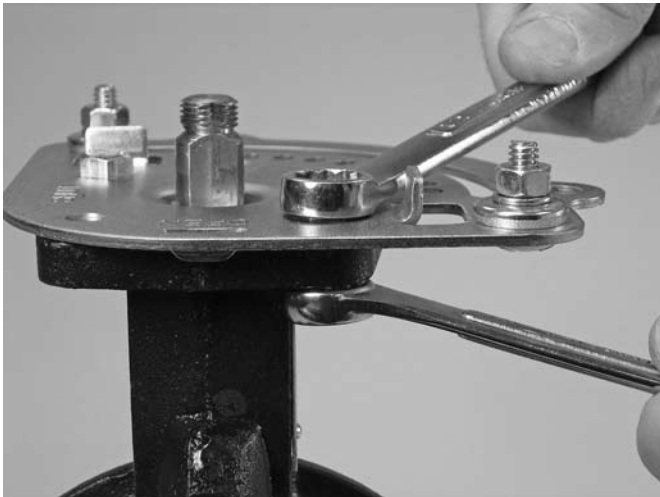

3. Remove the hex nuts with captive-toothed lock washers (Item 3) from the hex-head screws (Item 7) that attach the plate (Item 2) to the valve body mounting flange.



4. Remove the plate (Item 2) from the valve body mounting flange.
5. The valve is now ready for conversion to a Tamper-Resistant Handle or a Gear Operator. In addition, the "Stem Seal Replacement" instructions can be performed, the thermal barrier kit can be installed, or the insulation extension kit can be installed.

CAUTION

- **DO NOT attempt to operate a Vic-300 MasterSeal Butterfly Valve without a handle or gear operator installed.**
Failure to follow this instruction will cause improper valve operation and damage to the stem.

Vic®-300 MasterSeal™ Butterfly Valves

SERIES 761

LEVER LOCK HANDLE REMOVAL FOR 8-INCH/219.1-MM VALVES

WARNING



- Read and understand all instructions before attempting to remove the Lever Lock Handle assembly.

Failure to follow all instructions could result in serious personal injury and/or property damage.

WARNING



- THE PUMP MUST BE SHUT OFF to prevent flow from passing through the valve during the following procedures.

Failure to follow this instruction could cause product failure, resulting in serious personal injury and/or property damage.

Removal of the Lever Lock Handle can be performed without removing the valve from the piping system. **THE PUMP MUST BE SHUT OFF** to prevent flow from passing through the valve during removal of the Lever Lock Handle.

LEVER LOCK HANDLE PARTS LIST

Item No.	Qty.	Description
1	1	Lever Lock Handle Assembly
2	1	Plate
3	2	Hex Head Screw (5/16 - 18 UNC x 1-inch Long)
4	5	Lock Washer (5/16-inch)
5	5	Hex Nut (5/16 - 18 UNC)
6	1	Hex-Head Screw (5/16 - 18 UNC x 2-inches Long)
7	1	Round-Head, Square-Neck Bolt
8	2	Flat Washer (1/8-inch Thick x 3/4-inch OD x 1/32-inch ID)
9	1	Key

LEVER LOCK HANDLE ASSEMBLY DRAWING

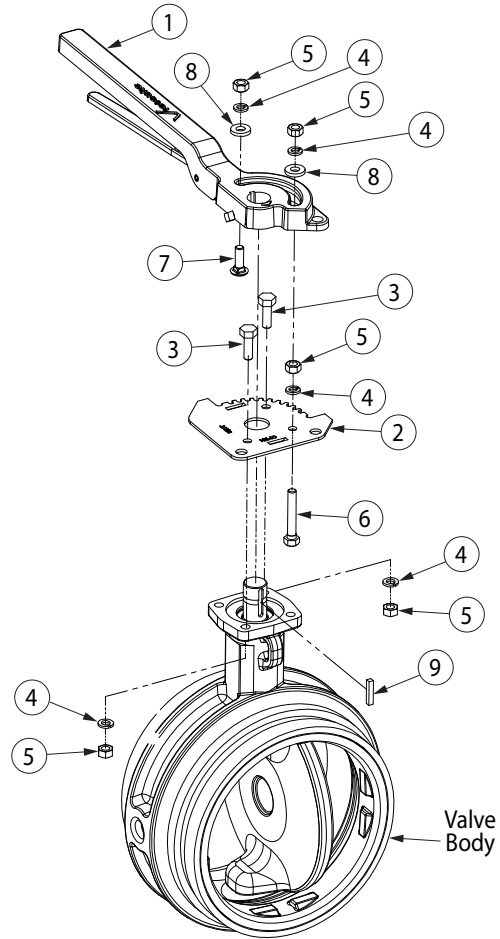

Exaggerated for clarity



1. Remove the hex nut (Item 5), lock washer (Item 4), and flat washer (Item 8) from the hex-head screw (Item 6), as shown above.

Vic[®]-300 MasterSeal[™] Butterfly Valves

SERIES 761



2. Loosen the set screw on the side of the handle (Item 1), as shown above.
- 2a. Remove the Lever Lock Handle assembly from the plate.

NOTICE

- The stem contains a key that is essential for re-installation of a handle or a gear operator. Use care to prevent misplacement of this key.



3. Remove the hex nuts (Item 5) and lock washers (Item 4) from the two hex-head screws (Item 3). In addition, remove the hex nut (Item 5) and lock washer (Item 4) from the hex-head screw (Item 6) to permit removal of the plate from the valve body mounting flange.

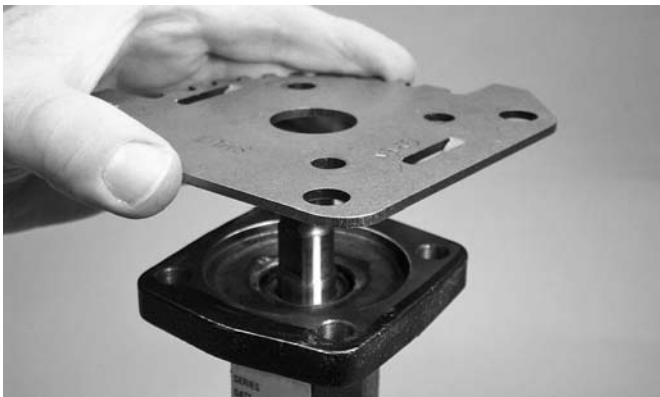

4. Remove the plate (Item 2) from the valve body mounting flange.

5. The valve is now ready for conversion to a Tamper-Resistant Handle or a Gear Operator. In addition, the "Stem Seal Replacement" instructions can be performed, the thermal barrier kit can be installed, or the insulation extension kit can be installed.

CAUTION

- **DO NOT attempt to operate a Vic-300 MasterSeal Butterfly Valve without a handle or gear operator installed.**
- Failure to follow this instruction will cause improper valve operation and damage to the stem.

Vic®-300 MasterSeal™ Butterfly Valves

SERIES 761

TAMPER-RESISTANT HANDLE KIT INSTALLATION FOR 2 – 6-INCH/60.3 – 168.3-MM VALVES WITH 10-POSITION HANDLES

WARNING



- Read and understand all instructions before attempting to install any Victaulic accessory kits.

Failure to follow all instructions could result in serious personal injury and/or property damage.

WARNING



- THE PUMP MUST BE SHUT OFF to prevent flow from passing through the valve during the following procedures.

Failure to follow this instruction could cause product failure, resulting in serious personal injury and/or property damage.

The tamper-resistant handle kit can be installed without removing the valve from the piping system. **THE PUMP MUST BE SHUT OFF** to prevent flow from passing through the valve during the following procedures.

CONTENTS OF TAMPER-RESISTANT HANDLE KIT

Item No.	Qty.	Description
1	1	Tamper-Resistant Handle
2	1	Plate
3	2	Round-Head, Square-Neck Bolt (¼ – 20 UNC x ¾-inch Long)
4	4	Spring Washer
5	1	Tamper-Resistant Nut
6	2	Lock Washer (¼ inch)
7	2	Hex Nut (¼ – 20 UNC)
8	2	Self-Clinching Nut (⅝ – 18 UNC)
9	2	Breakaway Security Bolt (⅝ – 18 UNC x ¾-inch Long)
10	1	Detent Screw
11	1	Washer
12	2	Memory Stop Washer

TAMPER-RESISTANT HANDLE ASSEMBLY DRAWING

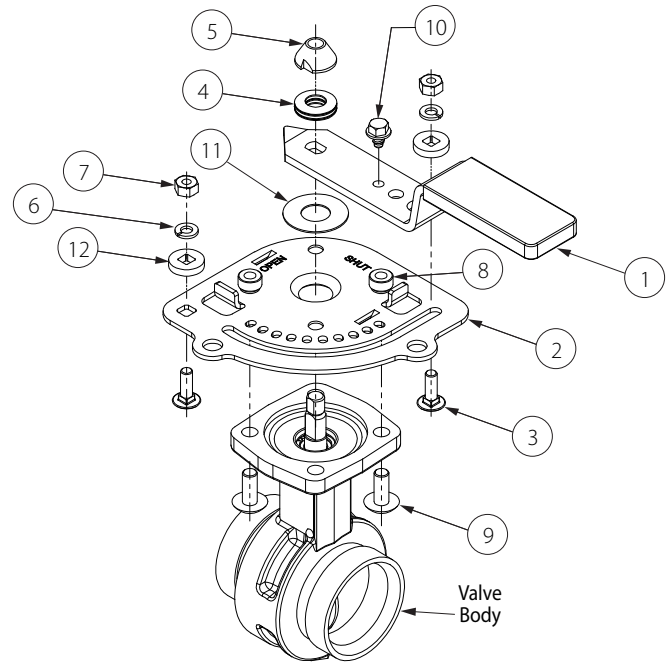

Exaggerated for Clarity

- Place the disc in the fully-open or fully-closed position.
- Remove the handle assembly by following the “10-Position Handle Removal for 2 – 6-inch/60.3 – 168.3-mm Valves” section.



- Install the plate (Item 2) over the stem assembly and onto the valve body mounting flange. Make sure two holes in the plate align with two holes in the valve body mounting flange. **NOTE:** If the plate is installed incorrectly, it will not seat evenly on the valve body mounting flange.

* Loctite is a registered trademark of the Henkel Corporation and 262 is a trademark of the Henkel Corporation

Vic®-300 MasterSeal™ Butterfly Valves

SERIES 761

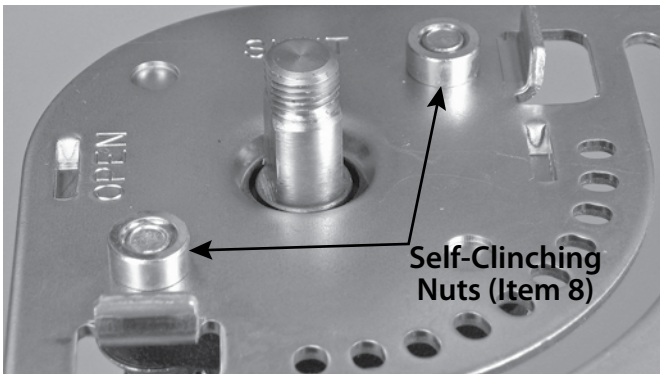

4. Apply Loctite 262* (or equivalent) to the two breakaway security bolts (Item 9). Insert a breakaway security bolt (Item 9) through the two holes in the valve body mounting flange and into the plate (Item 2) where the self-clinching nuts (Item 8) are pressed into the plate (Item 2). Hand-tighten the breakaway security bolts (Item 9).



5. Tighten the breakaway security bolts (Item 9) completely until the hex portion breaks away, leaving a flush, tamper-resistant head.



6. Place the washer (Item 11) over the stem assembly.



7. Place the tamper-resistant handle (Item 1) onto the stem assembly. Make sure the detent screw (Item 10) of the tamper-resistant handle faces toward the detents of the plate, as shown above.

* Loctite is a registered trademark of the Henkel Corporation and 262 is a trademark of the Henkel Corporation

Vic®-300 MasterSeal™ Butterfly Valves

SERIES 761

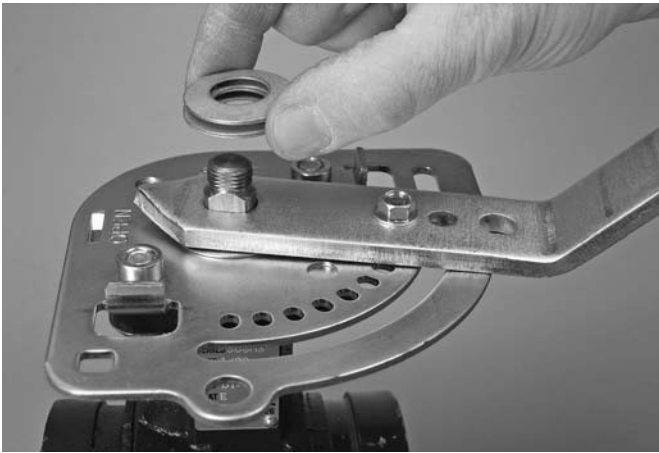

10. Using a spanner wrench, tighten the tamper-resistant nut (Item 5) completely.

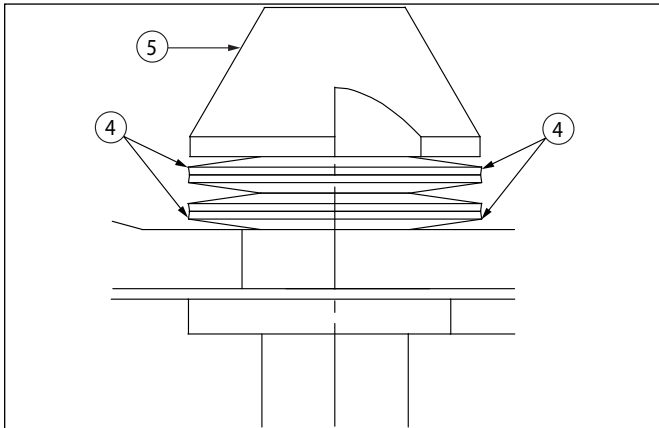

⚠ CAUTION

- **DO NOT** attempt to remove a tamper-resistant handle from the valve.
- Attempting to remove a tamper-resistant handle will cause damage to the valve, resulting in leakage and property damage.



8. Install the spring washers (Item 4) over the stem assembly. Make sure the sets of spring washers are installed with the outside edges touching, as shown in the drawing and photo above.
9. Apply Loctite 262* (or equivalent) to the tamper-resistant nut (Item 5). Install the tamper-resistant nut (Item 5) onto the stem assembly.

NOTE: The valve may be padlocked now in the open or shut position.

Vic[®]-300 MasterSeal[™] Butterfly Valves

SERIES 761

TAMPER-RESISTANT HANDLE KIT INSTALLATION FOR 8-INCH/219.1-MM VALVES WITH LEVER LOCK HANDLES

TAMPER-RESISTANT HANDLE ASSEMBLY DRAWING

⚠ WARNING



- Read and understand all instructions before attempting to install any Victaulic accessory kits.

Failure to follow all instructions could result in serious personal injury and/or property damage.

⚠ WARNING



- **THE PUMP MUST BE SHUT OFF** to prevent flow from passing through the valve during the following procedures.

Failure to follow this instruction could cause product failure, resulting in serious personal injury and/or property damage.

The tamper-resistant handle kit can be installed without removing the valve from the piping system. **THE PUMP MUST BE SHUT OFF** to prevent flow from passing through the valve during the following procedures.

CONTENTS OF TAMPER-RESISTANT HANDLE KIT

Item No.	Qty.	Description
1	1	Tamper-Resistant Handle
2	1	Plate
3	1	Grooved Drive Pin
4	2	Tamper-Resistant Torx Screw (5/16 – 18 UNC x 1-inch Long)
5	2	Lock Washer (5/16-inch)
6	2	Tamper-Resistant Nut with Breakaway Hex (5/16 – 18 UNC)
7	1	Key

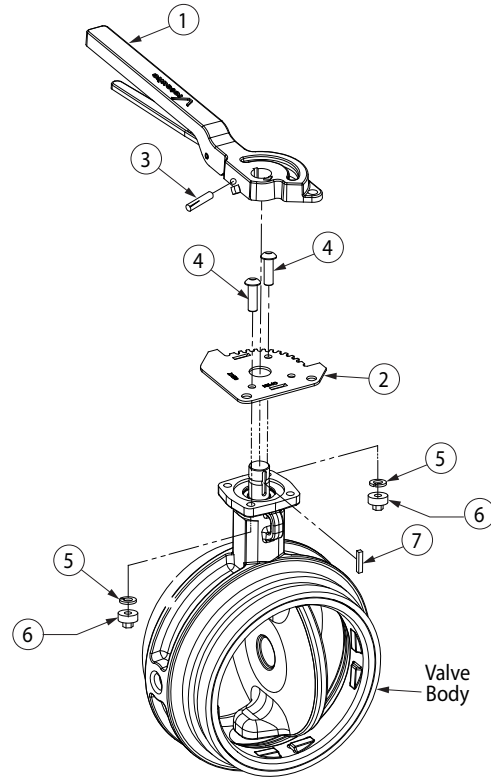

Exaggerated for clarity

1. Place the disc in the fully-open or fully-closed position.
2. Remove the handle assembly by following the “Lever Lock Handle Removal for 8-inch/219.1-mm Valves” section.



3. Install the plate (Item 2) over the stem assembly and onto the valve body mounting flange. Make sure two holes in the plate align with two holes in the valve body mounting flange. **NOTE:** If the plate is installed incorrectly, it will not seat evenly on the valve body mounting flange.

Vic®-300 MasterSeal™ Butterfly Valves

SERIES 761



4. Insert a tamper-resistant torx screw (Item 4) through the two holes in the plate and into the valve body mounting flange. Place a lock washer (Item 5) onto the end of each tamper-resistant torx screw, and thread a tamper-resistant nut (Item 6) onto the end of each torx screw until hand tight. DO NOT tighten the torx screws completely at this time.



5. Insert the key into the keyway in the stem. Place the tamper-resistant handle (Item 1) onto the stem assembly. Make sure the arm of the tamper-resistant handle faces toward the teeth of the plate, as shown above.



6. Insert the grooved drive pin (Item 3) into the hole in the tamper-resistant handle, as shown above. Drive the pin completely into the handle.



7. Tighten the set screw on the side of the handle (next to the hole for the grooved drive pin), as shown above.
8. Close the valve disc to ensure the tamper-resistant handle makes full contact with the flat portion of the plate that extends past the teeth.



9. Using a tamper-resistant torx driver and an open-end wrench, tighten the tamper-resistant nuts until the hex portion breaks away, leaving a flush, tamper-resistant head.

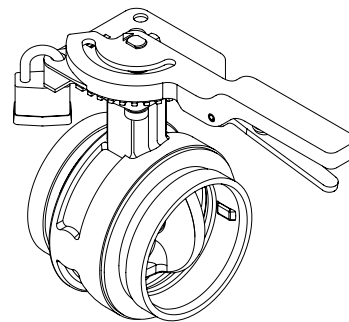

NOTE: The valve may be padlocked now in the open or shut position.

CAUTION

- DO NOT attempt to remove a tamper-resistant handle from the valve.

Attempting to remove a tamper-resistant handle will cause damage to the valve, resulting in leakage and property damage.

Vic®-300 MasterSeal™ Butterfly Valves

SERIES 761

TELESCOPIC HANDLE KIT INSTALLATION FOR 10 – 12-INCH/273.0 – 323.9-MM VALVES

⚠ WARNING



- Read and understand all instructions before attempting to install any Victaulic accessory kits.
- Failure to follow all instructions could result in serious personal injury and/or property damage.

⚠ WARNING



- THE PUMP MUST BE SHUT OFF to prevent flow from passing through the valve during the following procedures.

Failure to follow this instruction could cause product failure, resulting in serious personal injury and/or property damage.

The telescopic handle kit can be installed without removing the valve from the piping system. **THE PUMP MUST BE SHUT OFF** to prevent flow from passing through the valve during the following procedures.

CONTENTS OF TELESCOPIC HANDLE KIT

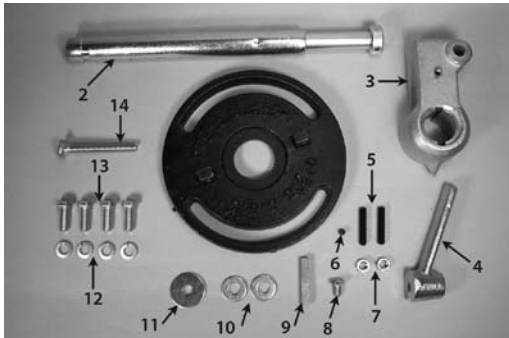

Item No.	Qty.	Description
1	1	Dial Plate
2	1	Telescopic Handle Assembly
2a	1	Sleeve
2b	1	Rod
2c	1	Knurled Ring
2d	1	Spring Pin
3	1	Handle Hub
4	1	Locking Lever
5	2	Socket Set Screw (5/16 – 18 UNC x 1 1/2-inches Long)
6	1	Socket Set Screw (1/4 – 20 UNC x 5/16-inch Long)
7	2	Hex Nut (5/16 – 18 UNC)
8	1	Hex-Head Cap Screw (5/16 – 18 UNC x 1/2-inch Long)
9	1	Key (5/16-inch Square x 1 7/8-inches Long)
10	2	Flat Washer (3/8-inch Diameter)
11	1	Flat Washer (1 3/8-inches OD x 3/8-inch ID x 0.100-inch Thick)
12	4	Lock Washer (3/8-inch Diameter)
13	4	Hex-Head Cap Screw (3/8 – 16 UNC x 1-inch Long)
14	1	Carriage Bolt (3/8 – 16 UNC x 3-inches Long)

CONTENTS OF OPTIONAL MEMORY POINTER ASSEMBLY KIT

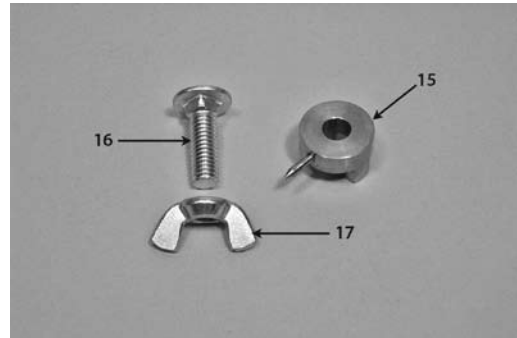

Item No.	Qty.	Description
15	1	Memory Pointer
16	1	Carriage Bolt (3/8 – 16 UNC x 1 1/4-inches Long)
17	1	Wing Nut (3/8 – 16 UNC)

TELESCOPIC HANDLE ASSEMBLY DRAWING

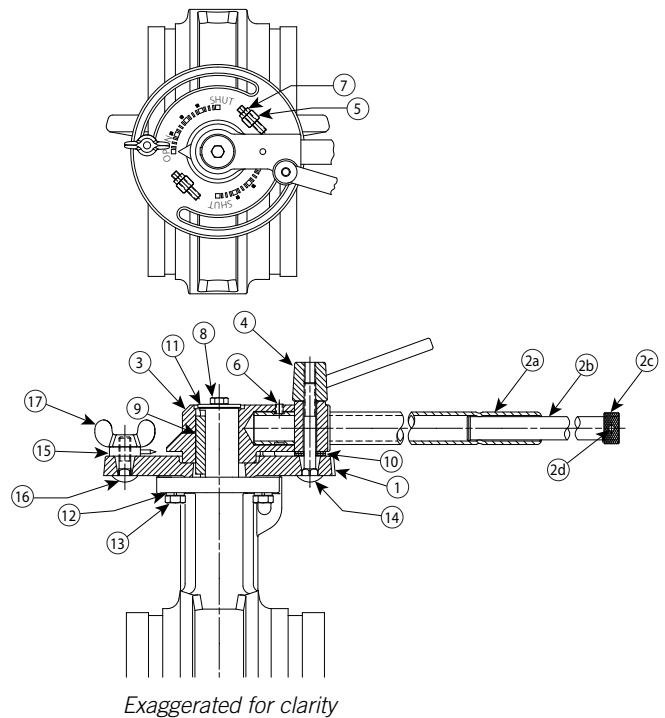

Vic®-300 MasterSeal™ Butterfly Valves

SERIES 761



1. Install the dial plate (Item 1) onto the valve so that the holes in the dial plate align with the holes in the valve body mounting flange. Make sure the "OPEN" markings align with the valve inlet and outlet (refer to the photos shown above).



2. Place one lock washer (Item 12) onto each of the four hex-head cap screws (Item 13). Thread the hex-head cap screws up through the valve body mounting flange and into the tapped bosses of the dial plate.

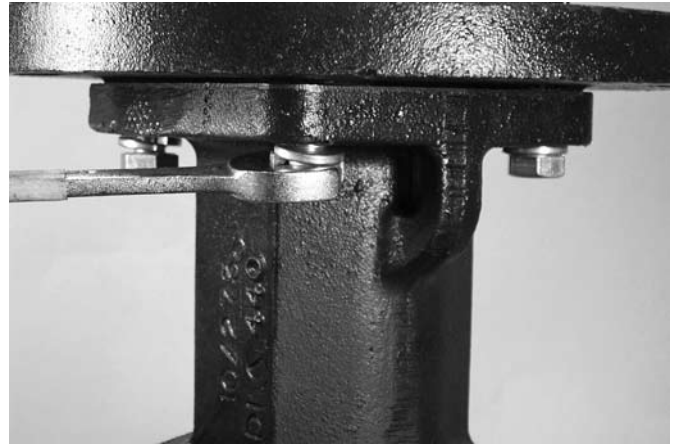

3. Using a wrench, tighten the four hex-head cap screws evenly until the lock washers become flattened.



4. Install the key (Item 9) into the keyway in the stem, as shown above.

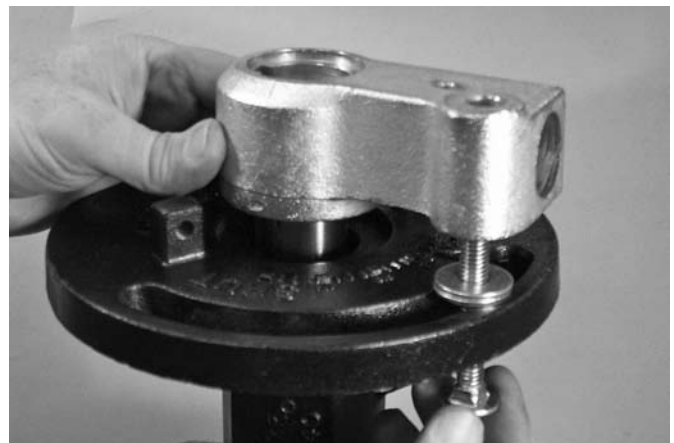

5. Make sure the valve disc is in the "OPEN" position. Insert the carriage bolt (Item 14) up through the bottom of the dial plate. Place the two flat washers (Item 10) onto the carriage bolt.
- 5a. Align the pointer of the handle hub (Item 3) with the "OPEN" position marking on the dial plate. Install the handle hub onto the stem and carriage bolt, as shown above.

Vic[®]-300 MasterSeal[™] Butterfly Valves

SERIES 761



6. Install the locking lever (Item 4) onto the carriage bolt, as shown above. DO NOT tighten the locking lever completely at this time.

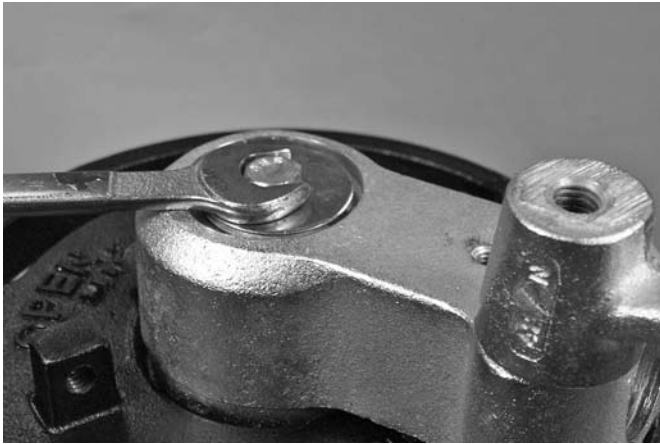

7. Secure the handle hub to the stem with the flat washer (Item 11) and hex-head screw (Item 8), as shown above.

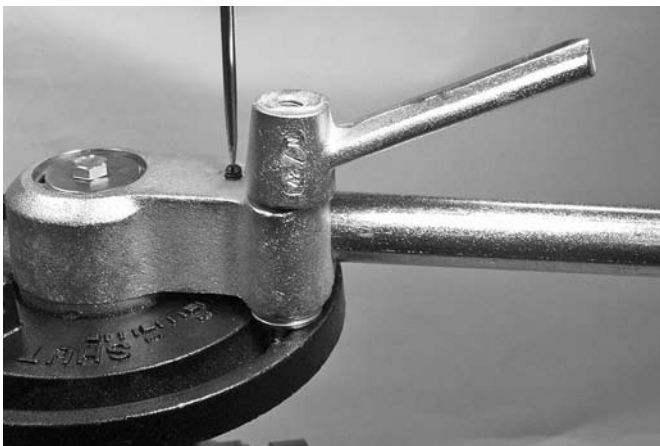

8. Insert the telescopic handle assembly (Item 2) into the handle hub. Tighten the socket set screw (Item 6) into the handle hub to secure the telescopic handle assembly in position.

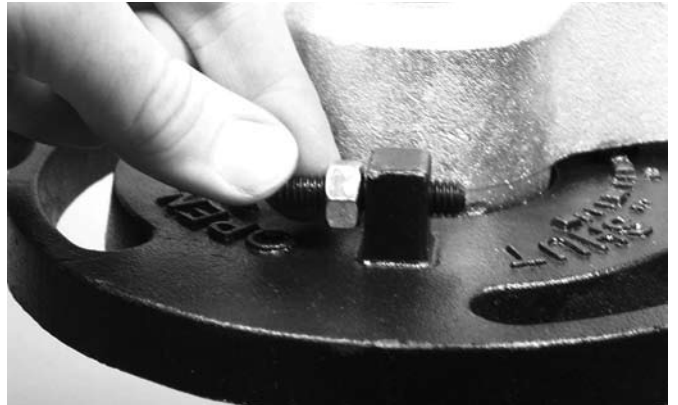

9. Thread a hex nut (Item 7) onto a socket set screw (Item 5). Thread the socket set screw halfway into the travel limit boss of the dial plate, as shown above.

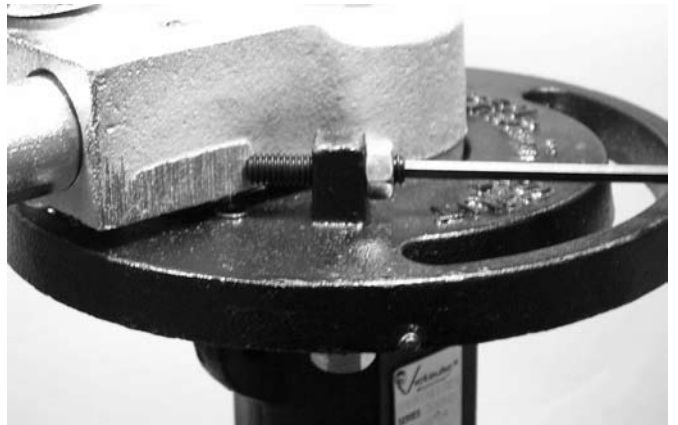

10. Make sure the valve disc is in the "OPEN" position. Turn the socket set screw until it contacts the handle hub, as shown above.

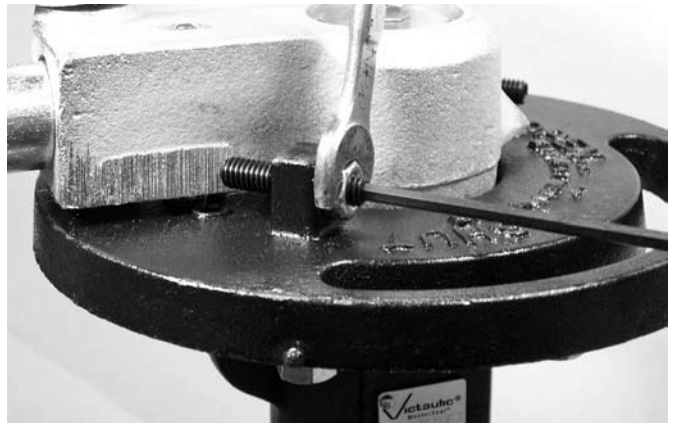

11. While holding the socket set screw in position, tighten the hex nut against the travel limit boss to set the "FULL OPEN" travel stop, as shown above.
12. For setting the "FULL SHUT" travel stop, close the valve until the pointer aligns with the "SHUT" marking. Thread the remaining hex nut (Item 7) onto the socket set screw (Item 5). Thread the socket set screw halfway into the travel limit boss on the opposite side of the dial plate.

Vic®-300 MasterSeal™ Butterfly Valves

SERIES 761

- 12a. Turn the socket set screw until it contacts the handle hub.
- 12b. While holding the socket set screw in position, tighten the hex nut against the travel limit boss to set the "FULL SHUT" travel stop.
13. Place the valve back into service.



14. After placing the valve disc in the operating position, tighten the locking lever completely to maintain the position.

OPTIONAL MEMORY POINTER INSTALLATION

1. Using the telescopic handle, move the disc to the operating position.



2. Insert the carriage bolt (Item 16) up through the slot in the dial plate (adjacent to the pointer of the handle hub).
- 2a. Install the memory pointer (Item 15) onto the carriage bolt. Make sure the memory pointer and the pointer of the handle hub are aligned.
- 2b. Thread the wing nut (Item 17) onto the carriage bolt and tighten completely.

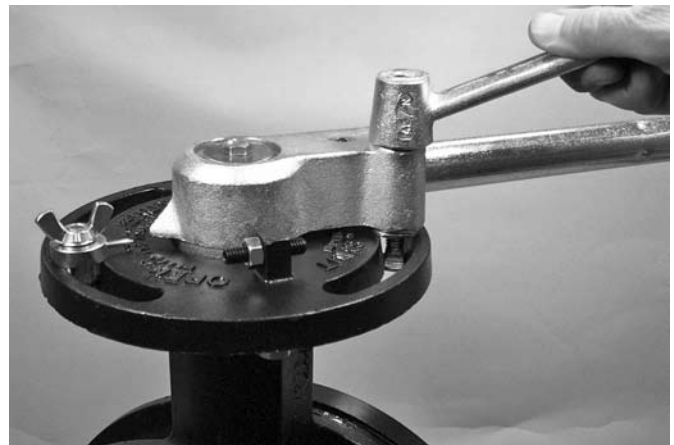

3. When the memory pointer is located at the proper position, tighten the locking lever to maintain the position.

Vic[®]-300 MasterSeal[™] Butterfly Valves

SERIES 761

GEAR OPERATOR INSTALLATION FOR 2 – 12-INCH/60.3 – 323.9-MM VALVES

⚠ WARNING



- Read and understand all instructions before attempting to install any Victaulic accessory kits.

Failure to follow all instructions could result in serious personal injury and/or property damage.

⚠ WARNING



- **THE PUMP MUST BE SHUT OFF** to prevent flow from passing through the valve during the following procedures.

Failure to follow this instruction could cause product failure, resulting in serious personal injury and/or property damage.

The gear operator can be installed without removing the valve from the piping system. **THE PUMP MUST BE SHUT OFF** to prevent flow from passing through the valve during the following procedures.

CONTENTS OF GEAR OPERATOR KIT



NOTE: The gear operator for a 4-inch/114.3-mm valve is shown. Therefore, Item 4 (Key) is not shown

Item No.	Qty.	Description
1	1	Gear Operator
2	1	Handwheel
3	1	Drive Bushing
4	1	Key *
5	4	Lock Washer (M8)
6	4	Hex-Head Screw (M8 x 20-mm Long)

* Not applicable for 2 – 6-inch/60.3 – 168.3-mm Sizes

GEAR OPERATOR ASSEMBLY DRAWING

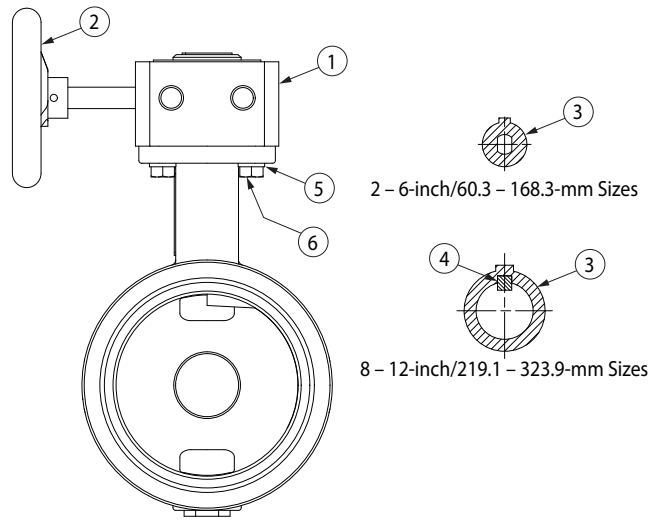

Exaggerated for clarity



NOTE: For 10-inch/273.0-mm and 12-inch/323.9-mm Vic-300 MasterSeal Butterfly Valves, the handwheel is not attached to the shaft. To attach the handwheel to the shaft, align the holes in the handwheel with the holes in the shaft. Drive the roll pin (provided) completely into the handwheel and shaft.

Vic®-300 MasterSeal™ Butterfly Valves

SERIES 761



1. Place the valve disc in the OPEN position, and turn the handwheel of the gear operator until the pointer is pointing toward the "OPEN" position, as shown above. **NOTE:** For valves currently installed in the system, refer to the position of the stem. For 2 – 6-inch/60.3 – 168.3-mm sizes, the flats of the stem will be parallel to the sides of the valve when the disc is in the "OPEN" position. For 8 – 12-inch/219.1 – 323.9-mm sizes, the key in the stem will face toward one end of the valve when the disc is in the "OPEN" position.



2. Insert the drive bushing into the gear operator, as shown above. Place the gear operator/drive bushing assembly on top of the valve body by aligning the four holes of the gear operator with the four holes in the valve body.

NOTE: For 8 – 12-inch/219.1 – 323.9-mm sizes, install the key into the keyway in the stem. Insert the drive bushing into the gear operator. Place the gear operator/drive bushing assembly on top of the valve body by aligning the four holes of the gear operator with the four holes in the valve body.



3. Install a lock washer (Item 5) onto each of the four hex-head screws (Item 6). Thread the hex-head screws up through the holes in the valve body mounting flange and into the gear operator.



4. Using a wrench, tighten the four hex-head screws evenly until the lock washers become flattened.
5. Turn the handle of the gear operator to ensure proper operation.

Vic[®]-300 MasterSeal[™] Butterfly Valves

SERIES 761

ADJUSTING AND SETTING THE CLOSED TRAVEL LIMIT STOPS OF THE GEAR OPERATOR



1. Remove the dust cap from the right side of the gear operator.



2. Loosen the hex lock nut (counterclockwise) located on the right side of the gear operator.



3. Using an allen wrench, loosen the internal set screw approximately three turns (counterclockwise).
4. Turn the handwheel in the clockwise direction to place the disc in the closed (shut) position. The "closed" position is reached when the pointer on top of the gear operator reaches the "shut" marking.



5. Using the allen wrench, tighten the internal set screw (clockwise) until it contacts the internal quadrant gear.



6. Tighten the hex lock nut (clockwise).
7. Verify proper operation of the gear operator by turning the handwheel. Repeat steps 5 and 6, if necessary.



8. Replace the dust cap.

Vic®-300 MasterSeal™ Butterfly Valves

SERIES 761

ADJUSTING AND SETTING THE OPEN TRAVEL LIMIT STOPS OF THE GEAR OPERATOR



1. Remove the dust cap from the left side of the gear operator.



2. Loosen the hex lock nut (counterclockwise) located on the left side of the gear operator.



3. Using an allen wrench, loosen the internal set screw approximately three turns (counterclockwise).
4. Turn the handwheel in the counterclockwise direction to place the disc in the open position. The "open" position is reached when the position indicator is 90° from the correctly adjusted closed position.



5. Using the allen wrench, tighten the internal set screw (clockwise) until it contacts the internal quadrant gear.



6. Tighten the hex lock nut.
7. Verify proper operation of the gear operator by turning the handwheel.



8. Replace the dust cap.

Vic®-300 MasterSeal™ Butterfly Valves

SERIES 761

MEMORY STOP KIT INSTALLATION FOR 2 – 12-INCH/60.3 – 323.9-MM GEAR OPERATED VALVES

⚠ WARNING



- Read and understand all instructions before attempting to install any Victaulic accessory kits.

Failure to follow all instructions could result in serious personal injury and/or property damage.

⚠ WARNING



- **THE PUMP MUST BE SHUT OFF** to prevent flow from passing through the valve during the following procedures.

Failure to follow this instruction could cause product failure, resulting in serious personal injury and/or property damage.

The memory stop kit can be installed without removing the valve from the piping system. **THE PUMP MUST BE SHUT OFF** to prevent flow from passing through the valve during the following procedures.

CONTENTS OF MEMORY STOP KIT

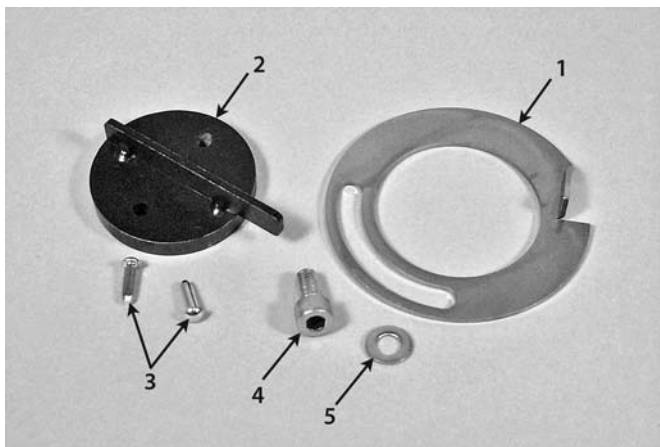

Item No.	Qty.	Description
1	1	Memory Stop
2	1	Position Indicator
3	2	Drive Pin
4	1	Bolt
5	1	Flat Washer



1. Pry off the plastic position-indicator cap.



2. Remove the set screw from the top of the gear operator, as shown above.



3. Install the memory stop onto the gear operator. Make sure the tapped hole is centered in the slot of the memory stop, as shown above.

Vic®-300 MasterSeal™ Butterfly Valves

SERIES 761

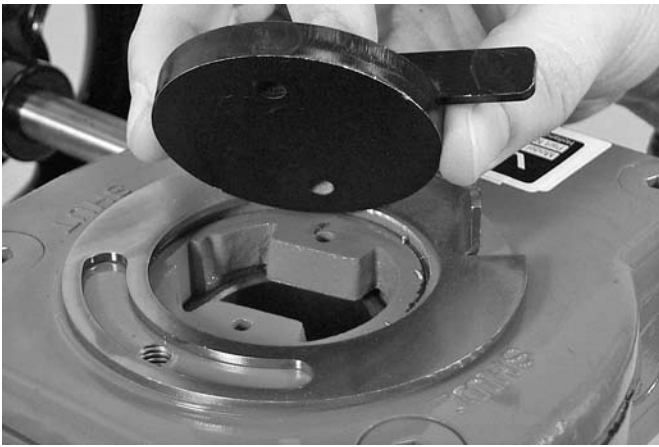

4. Install the position indicator onto the gear operator. Make sure the holes in the memory stop align with the holes in the gear operator.



7. Slide the flat, raised portion of the memory stop toward the position indicator until they contact.



5. Insert the drive pins into the holes in the position indicator and gear operator. Tap the drive pins into the gear operator.



8. Tighten the bolt completely to maintain the position of the memory stop.



6. Install the bolt with the flat washer into the tapped hole in the gear operator. Do not tighten the bolt completely at this time. Turn the handwheel to place the disc in the desired position (clockwise to close and counterclockwise to open).

NOTE: To re-adjust the memory stop, loosen the bolt for the memory stop. Turn the handwheel to place the disc in the desired position (clockwise to close and counterclockwise to open). Follow steps 7 and 8 on this page.

Vic®-300 MasterSeal™ Butterfly Valves

SERIES 761

THERMAL BARRIER KIT INSTALLATION FOR 2 – 12-INCH/60.3 – 323.9-MM VALVES

⚠ WARNING



- Read and understand all instructions before attempting to install any Victaulic kits.

Failure to follow all instructions could result in serious personal injury and/or property damage.

⚠ WARNING



- **THE PUMP MUST BE SHUT OFF** to prevent flow from passing through the valve during the following procedures.

Failure to follow this instruction could cause product failure, resulting in serious personal injury and/or property damage.

NOTICE

- The following instruction shows a typical installation of the thermal barrier kit on a gear-operated valve. When necessary, this thermal barrier kit can also be installed onto valves containing Lever Lock Handles, 10-Position Handles, and Telescopic Handles.
- The thermal barrier kit contains two gaskets. One gasket covers 2 – 8-inch/60.3 – 219.1-mm valve sizes, and the other gasket covers 10 – 12-inch/273.0 – 323.9-mm valve sizes. Make sure the correct gasket size is used for the corresponding valve size.

THERMAL BARRIER KIT ASSEMBLY DRAWING

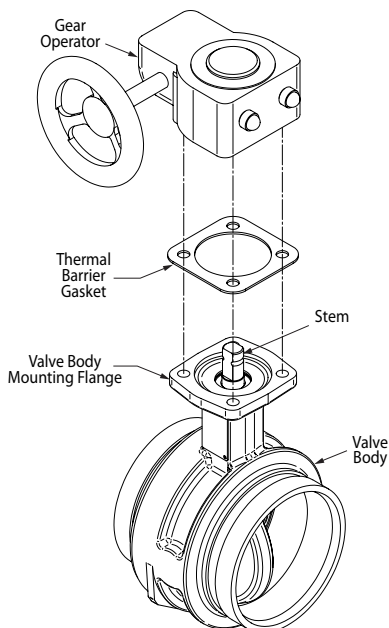

Exaggerated for clarity

Removal of the gear operator can be performed without removing the valve from the piping system. **THE PUMP MUST BE SHUT OFF** to prevent flow from passing through the valve during the following procedures.

Note the current orientation of the gear operator before proceeding with the following steps. As a reference for gear operator re-installation, place a mark on the gear operator, the stem, and the valve body mounting flange with a permanent marker or paint pen.

1. Place the valve disc in the **OPEN** position by turning the handwheel of the gear operator until the pointer is pointing toward the **OPEN** position.
2. Remove the four hex-head screws and lock washers that attach the gear operator to the valve body mounting flange.
3. Pull straight upward to remove the gear operator and drive bushing from the valve body mounting flange. **DO NOT REMOVE OR ROTATE THE STEM.**
4. Remove any debris from the valve body mounting flange.
5. Place the correct size thermal barrier gasket onto the valve body mounting flange, as shown in the sketch on this page. **NOTE:** The gasket should cover the entire valve body mounting flange (gasket will be slightly larger than the surface area of the valve body mounting flange).
6. **BEFORE RE-INSTALLING THE GEAR OPERATOR:** Refer to the position of the stem. For 2 – 6-inch/60.3 – 168.3-mm sizes, the flats of the stem will be parallel to the sides of the valve when the disc is in the **OPEN** position. For 8 – 12-inch/219.1 – 323.9-mm sizes, the key in the stem will face toward one end of the valve when the disc is in the **OPEN** position.
7. Insert the drive bushing into the gear operator.
8. Place the gear operator/drive bushing assembly on top of the valve body mounting flange in the same orientation as previously installed. Align the four holes of the gear operator with the four holes in the valve body mounting flange.

NOTE: For 8 – 12-inch/219.1 – 323.9-mm sizes, install the key into the keyway in the stem. Insert the drive bushing into the gear operator. Place the gear operator/drive bushing assembly on top of the valve body by aligning the four holes of the gear operator with the four holes in the valve body.

9. Apply a lock washer to each of the four hex-head screws. Thread the hex-head screws up through the valve body mounting flange and gear operator until finger-tight.
10. Tighten the four hex-head screws evenly until the lock washers are fully compressed and metal-to-metal contact occurs between the gear operator and the valve body mounting flange.
11. Turn the handle of the gear operator to ensure proper operation.

Vic®-300 MasterSeal™ Butterfly Valves

SERIES 761

INSULATION EXTENSION KIT FOR 2 - 8-INCH/ 60.3 - 219.1-MM GEAR-OPERATED VALVES

WARNING



- Read and understand all instructions before attempting to install any Victaulic accessory kits.
- Failure to follow all instructions could result in serious personal injury and/or property damage.

WARNING



- **THE PUMP MUST BE SHUT OFF** to prevent flow from passing through the valve during the following procedures.

Failure to follow this instruction could cause product failure, resulting in serious personal injury and/or property damage.

Removal of the gear operator can be performed without removing the valve from the piping system. **THE PUMP MUST BE SHUT OFF** to prevent flow from passing through the valve during the following procedures.

Vic-300 MasterSeal Butterfly Valves are designed to accept 2 inches/ 50 mm of insulation. When more than 2 inches/50 mm of insulation is required, the insulation extension kit should be utilized to provide clearance for the additional insulation.

CONTENTS OF INSULATION EXTENSION KIT FOR GEAR-OPERATED VALVES

Item No.	Quantity for 2 - 4-inch/ 60.3 - 114.3-mm Sizes	Quantity for 5 - 8-inch/ 141.3 - 219.1-mm Sizes	Description
1	1	1	Flat Washer
2	4	2	Spring Washer
3	1	1	Stem Adapter
4	4	4	Hex-Head Bolt
5	1	1	Spacer/Insulation Extension
6	4	4	Spring-Lock Washer
7	4	4	Hex Nut
8	0	2*	Key*
9	1	1	Cup-Point Set Screw
10	1	1	L-Key Hex Wrench (Not Shown)

* Key is for the 8-inch/219.1-mm valve size only

Items not called out in the drawings below are existing components that must be saved for re-installation of the gear operator assembly. Refer to the following page for kit installation instructions.

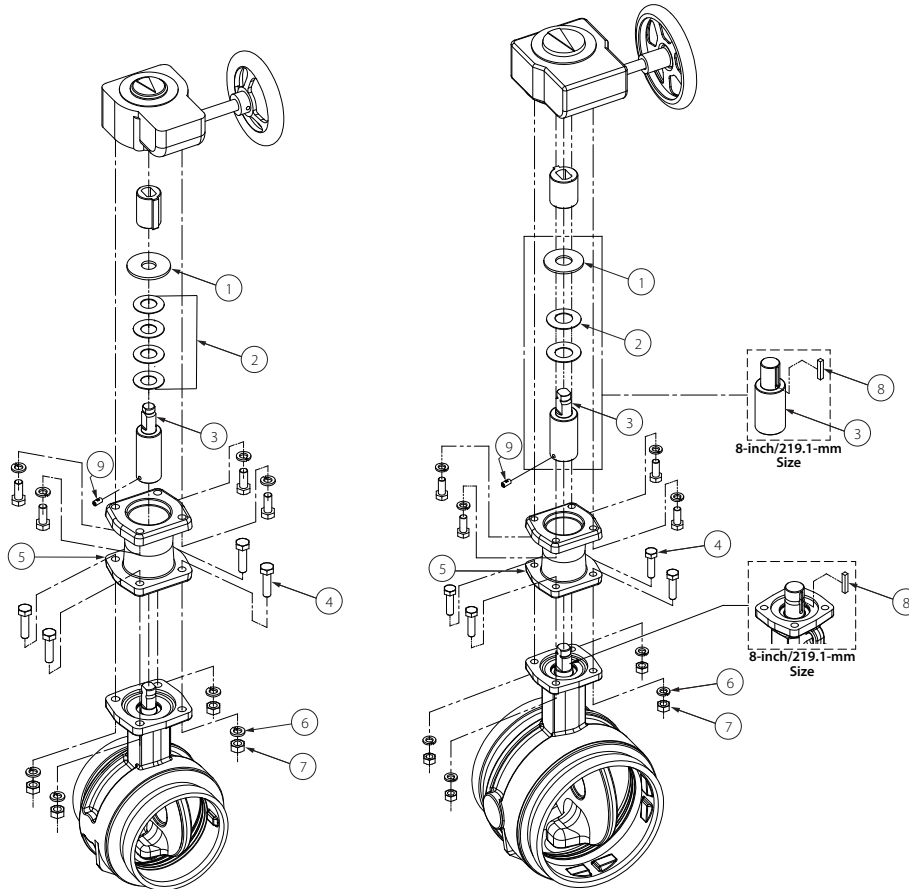

2 - 4-inch/60.3 - 114.3-mm Sizes

5 - 8-inch/141.3 - 219.1-mm Sizes

Vic[®]-300 MasterSeal[™] Butterfly Valves

SERIES 761

INSULATION EXTENSION KIT INSTALLATION FOR 2 – 8-INCH/60.3 – 219.1-MM GEAR-OPERATED VALVES

⚠ WARNING



- Read and understand all instructions before attempting to install any Victaulic accessory kits.

Failure to follow all instructions could result in serious personal injury and/or property damage.

⚠ WARNING



- THE PUMP MUST BE SHUT OFF to prevent flow from passing through the valve during the following procedures.

Failure to follow this instruction could cause product failure, resulting in serious personal injury and/or property damage.

Removal of the gear operator can be performed without removing the valve from the piping system. **THE PUMP MUST BE SHUT OFF** to prevent flow from passing through the valve during the following procedures.

Note the current orientation of the gear operator before proceeding with the following steps. **AS A REFERENCE FOR GEAR OPERATOR RE-INSTALLATION:** Place a mark on the gear operator, the stem, and the valve body mounting flange with a permanent marker or paint pen.

1. Place the valve disc in the **OPEN** position by turning the handwheel of the gear operator until the pointer is pointing toward the **OPEN** position.
2. Remove the four existing hex-head screws and lock washers that attach the gear operator to the valve body mounting flange. **NOTE:** These hex-head screws and lock washers are required for re-installation.
3. Pull straight upward to remove the gear operator and existing drive bushing from the valve body mounting flange. These items are required for re-installation. **DO NOT REMOVE OR ROTATE THE STEM.**
4. Remove any debris from the valve body mounting flange.
5. Place the stem adapter (Item 3) onto the stem. **NOTE:** For 8-inch/219.1-mm valves, remove the existing key from the keyway in the stem. Install a new key (Item 8), provided in the kit, into the keyway in the stem. Install the second key (Item 8), provided in the kit, into the stem adapter (Item 3).
6. Using the L-key hex wrench (provided with the kit), drive the cup-point set screw (Item 9) into the threaded hole in the stem adapter (Item 3).

7. Place the spacer/insulation extension (Item 5) onto the valve body mounting flange with the machined counterbore facing upward (away from the valve). Align the four holes of the spacer/insulation extension (Item 5) with the four holes in the valve body mounting flange.
8. Secure the spacer/insulation extension (Item 5) to the valve body mounting flange by using the four hex-head bolts, spring-lock washers and hex nuts (Items 4, 6, and 7) provided in the kit.

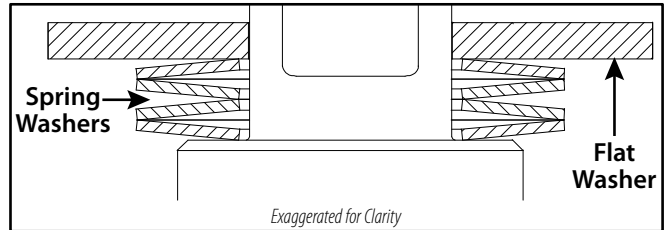

9. **FOR 2 - 4-INCH/60.3 - 114.3-MM VALVES ONLY:** Install the four spring washers (Item 2) onto the stem assembly. Make sure the sets of spring washers (Item 2) are installed with the outside edges touching, as shown in the drawing above.

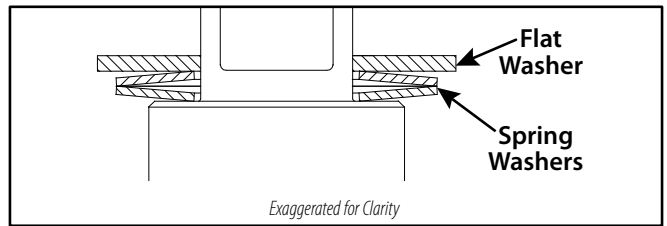

- 9a. **FOR 5 - 8-INCH/141.3 - 219.1-MM VALVES ONLY:** Install the two spring washers (Item 2) onto the stem assembly. Make sure the spring washers (Item 2) are installed with the outside edges touching, as shown in the drawing above.
10. Place the flat washer (Item 1) on top of the spring washers (Item 2).
11. Insert the existing drive bushing into the gear operator. **NOTE:** For 8-inch/219.1-mm valves, make sure the existing key is installed in the keyway in the stem. Insert the drive bushing into the gear operator.
12. Place the gear operator assembly onto the valve body mounting flange in the same orientation as previously installed. Insert the four existing hex-head screws with lock washers (removed in step 2) into the holes in the spacer/insulation extension and into the gear operator assembly.
13. Using a wrench, tighten the four hex-head screws evenly until the lock washers become flattened.
14. Turn the handle of the gear operator to ensure proper operation.

Vic®-300 MasterSeal™ Butterfly Valves

SERIES 761

INSULATION EXTENSION KIT FOR 2 - 6-INCH/ 60.3 - 168.3-MM VALVES WITH 10-POSITION HANDLES

WARNING



- Read and understand all instructions before attempting to install any Victaulic accessory kits.

Failure to follow all instructions could result in serious personal injury and/or property damage.

WARNING



- THE PUMP MUST BE SHUT OFF to prevent flow from passing through the valve during the following procedures.

Failure to follow this instruction could cause product failure, resulting in serious personal injury and/or property damage.

Removal of the 10-Position Handle can be performed without removing the valve from the piping system. **THE PUMP MUST BE SHUT OFF** to prevent flow from passing through the valve during the following procedures.

Vic-300 MasterSeal Butterfly Valves are designed to accept 2 inches/ 50 mm of insulation. When more than 2 inches/50 mm of insulation is required, the insulation extension kit should be utilized to provide clearance for the additional insulation.

CONTENTS OF INSULATION EXTENSION KIT FOR VALVES WITH 10-POSITION HANDLES

Item No.	Quantity	Description
1	1	Flat Washer
2	1	Stem Adapter
3	1	Spacer/Insulation Extension
4	4	Hex-Head Bolt
5	4	Spring-Lock Washer
6	4	Hex Nut
7	1	Cup-Point Set Screw
8	1	L-Key Hex Wrench (Not Shown)

Items not called out in the drawings below are existing components that must be saved for re-installation of the 10-Position Handle assembly.

Refer to the following page for kit installation instructions.

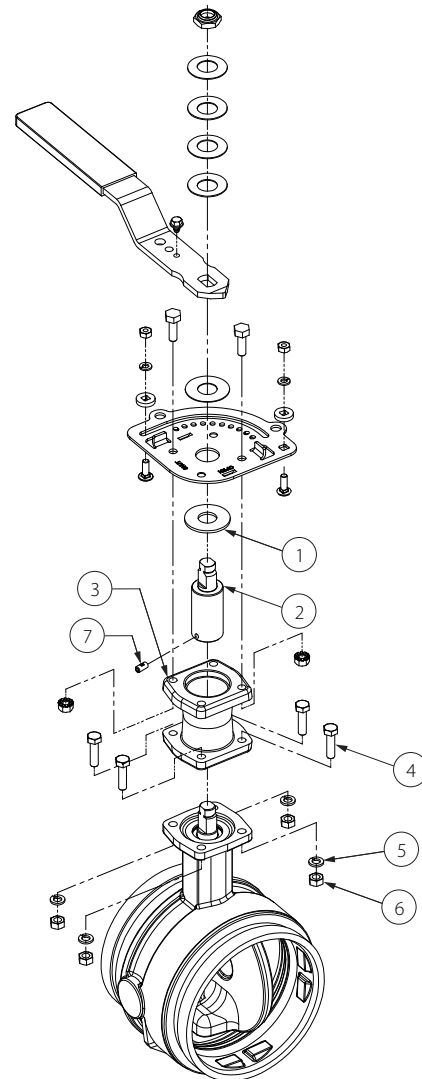

2 - 6-inch/60.3 - 168.3-mm Sizes

Vic[®]-300 MasterSeal[™] Butterfly Valves

SERIES 761

INSULATION EXTENSION KIT INSTALLATION FOR 2 – 6-INCH/60.3 – 168.3-MM VALVES WITH 10-POSITION HANDLES

⚠ WARNING



- Read and understand all instructions before attempting to install any Victaulic accessory kits.

Failure to follow all instructions could result in serious personal injury and/or property damage.

⚠ WARNING



- THE PUMP MUST BE SHUT OFF to prevent flow from passing through the valve during the following procedures.

Failure to follow this instruction could cause product failure, resulting in serious personal injury and/or property damage.

Removal of the 10-Position Handle can be performed without removing the valve from the piping system. **THE PUMP MUST BE SHUT OFF** to prevent flow from passing through the valve during the following procedures.

- Using the handle, place the valve disc in the **OPEN** position. **NOTE:** Using a paint stick or bright-colored marker, place a mark on the handle plate and the valve body to aid in re-installing the handle plate in the correct orientation.
- Follow the "10-Position Handle Removal for 2 - 6-inch/ 60.3 - 168.3-mm Valves" section in this manual to remove the handle assembly from the valve. **NOTE:** All components removed from the valve will be required for re-installation.
- Remove any debris from the valve body mounting flange.
- Place the stem adapter (Item 2) onto the stem.
- Using the L-key hex wrench (provided with the kit), drive the cup-point set screw (Item 7) into the threaded hole in the stem adapter (Item 2).
- Place the spacer/insulation extension (Item 3) onto the valve body mounting flange with the machined counterbore facing upward (away from the valve). Make sure the contoured ends of the spacer/insulation extension (Item 3) are matched up to the contoured ends of the valve body mounting flange, and align the four holes.
- Secure the spacer/insulation extension (Item 3) to the valve body mounting flange by using the four hex-head bolts, spring-lock washers and hex nuts (Items 4, 5, and 6) provided in the kit.
- Place the flat washer (Item 1), provided in the kit, into the counterbore of the spacer/insulation extension (Item 3).
- Place the existing handle plate onto the spacer/insulation extension (Item 3). Make sure the mark on the handle plate (made in step 1) is aligned with the mark on the valve body (made in step 1).
- Insert an existing hex-head screw through the holes in the existing handle plate and into the spacer/insulation extension (Item 3).
- Install an existing hex nut with captive-toothed lock washer onto the existing hex-head screws.
- Tighten the hex nuts with captive-toothed lock washer to secure the existing handle plate to the spacer/insulation extension (Item 3).
- Place the existing flat washer over the stem adapter (Item 2) and onto the existing handle plate.
- Install the existing 10-Position Handle onto the stem adapter (Item 2). Make sure the pointer of the handle is pointing to the **OPEN** marking on the plate.

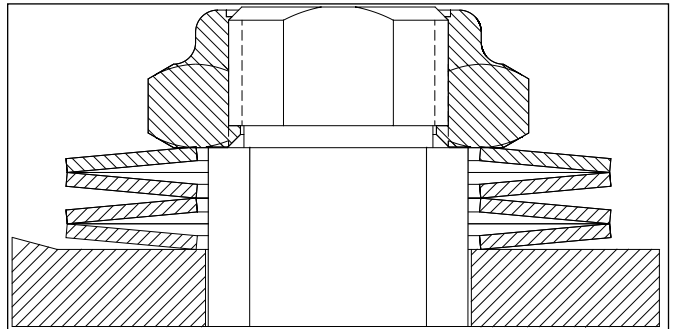

Exaggerated for clarity



- Install the existing spring washers onto the stem adapter (Item 2). Make sure the sets of spring washers are installed with the outside edges touching, as shown in the drawing and photo above.
- a. Install the existing lock nut onto the stem adapter (Item 2). Using a wrench, tighten the lock nut completely to secure the 10-Position Handle to the stem adapter (Item 2).
- Turn the 10-Position Handle to ensure proper operation.

Vic®-300 MasterSeal™ Butterfly Valves

SERIES 761

INSULATION EXTENSION KIT FOR 8-INCH/ 219.1-MM VALVES WITH LEVER LOCK HANDLES

⚠ WARNING



- Read and understand all instructions before attempting to install any Victaulic accessory kits.
- Failure to follow all instructions could result in serious personal injury and/or property damage.

⚠ WARNING



- THE PUMP MUST BE SHUT OFF to prevent flow from passing through the valve during the following procedures.

Failure to follow this instruction could cause product failure, resulting in serious personal injury and/or property damage.

Removal of the Lever Lock Handle can be performed without removing the valve from the piping system. **THE PUMP MUST BE SHUT OFF** to prevent flow from passing through the valve during the following procedures.

Vic-300 MasterSeal Butterfly Valves are designed to accept 2 inches/ 50 mm of insulation. When more than 2 inches/50 mm of insulation is required, the insulation extension kit should be utilized to provide clearance for the additional insulation.

CONTENTS OF INSULATION EXTENSION KIT FOR VALVES WITH LEVER LOCK HANDLES

Item No.	Quantity	Description
1	2	Key
2	1	Stem Adapter
3	1	Spacer/Insulation Extension
4	4	Hex-Head Bolt
5	4	Spring-Lock Washer
6	4	Hex Nut

Items not called out in the drawings below are existing components that must be saved for re-installation of the Lever Lock Handle assembly.

Refer to the following page for kit installation instructions.

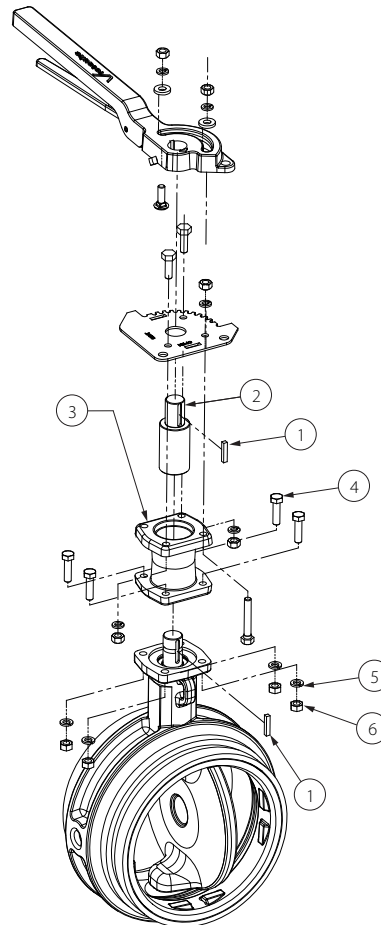

8-inch/219.1-mm Size

Vic®-300 MasterSeal™ Butterfly Valves

SERIES 761

INSULATION EXTENSION KIT INSTALLATION FOR 8-INCH/219.1-MM VALVES WITH LEVER LOCK HANDLES

⚠ WARNING



- Read and understand all instructions before attempting to install any Victaulic accessory kits.

Failure to follow all instructions could result in serious personal injury and/or property damage.

⚠ WARNING



- THE PUMP MUST BE SHUT OFF to prevent flow from passing through the valve during the following procedures.

Failure to follow this instruction could cause product failure, resulting in serious personal injury and/or property damage.

Removal of the Lever Lock Handle can be performed without removing the valve from the piping system. **THE PUMP MUST BE SHUT OFF** to prevent flow from passing through the valve during the following procedures.

- Using the handle, place the valve disc in the **OPEN** position.
NOTE: Using a paint stick or bright-colored marker, place a mark on the handle plate and the valve body to aid in re-installing the handle plate in the correct orientation.
- Follow the "Lever Lock Handle Removal for 8-inch/219.1-mm Valves" section in this manual to remove the handle assembly from the valve. **NOTE:** The memory stop hardware does not need to be removed in order to remove the handle. All components removed from the valve will be required for re-installation.
- Remove any debris from the valve body mounting flange.
- Remove the existing key from the keyway in the stem. Install a new key (Item 1), provided in the kit, into the keyway in the stem.
- Place the stem adapter (Item 2) onto the stem.
- Place the spacer/insulation extension (Item 3) onto the valve body mounting flange with the machined counterbore facing upward (away from the valve). Make sure the contoured ends of the spacer/insulation extension (Item 3) are matched up to the contoured ends of the valve body mounting flange, and align the four holes.
- Secure the spacer/insulation extension (Item 3) to the valve body mounting flange by using the four hex-head bolts, spring-lock washers and hex nuts (Items 4, 5, and 6) provided in the kit.
- Place the existing handle plate onto the spacer/insulation extension (Item 3). Make sure the mark on the handle plate (made in step 1) is aligned with the mark on the valve body (made in step 1).
- Insert the existing $\frac{5}{16}$ - 18 UNC x 2-inch long hex-head screw up through the hole in the spacer/insulation extension (Item 3) and the hole in the existing handle plate designated in the drawing above. Install an existing lock washer and existing hex nut onto this hex-head screw. Using a wrench, tighten the hex nut until the lock washer becomes flattened.
- Install the two $\frac{5}{16}$ - 18 UNC x 1-inch long hex-head screws into the existing handle plate and down through the two holes in the spacer/insulation extension (Item 3) designated in the drawing above. Install an existing lock washer and hex nut onto these hex-head screws. Using a wrench, tighten the hex nuts until the lock washers become flattened.
- Install the second key (Item 1), provided in the kit, into the keyway of the stem adapter (Item 2).
- Install the existing Lever Lock Handle assembly onto the stem adapter (Item 2). Make sure the pointer of the handle is pointing to the OPEN marking on the handle plate.

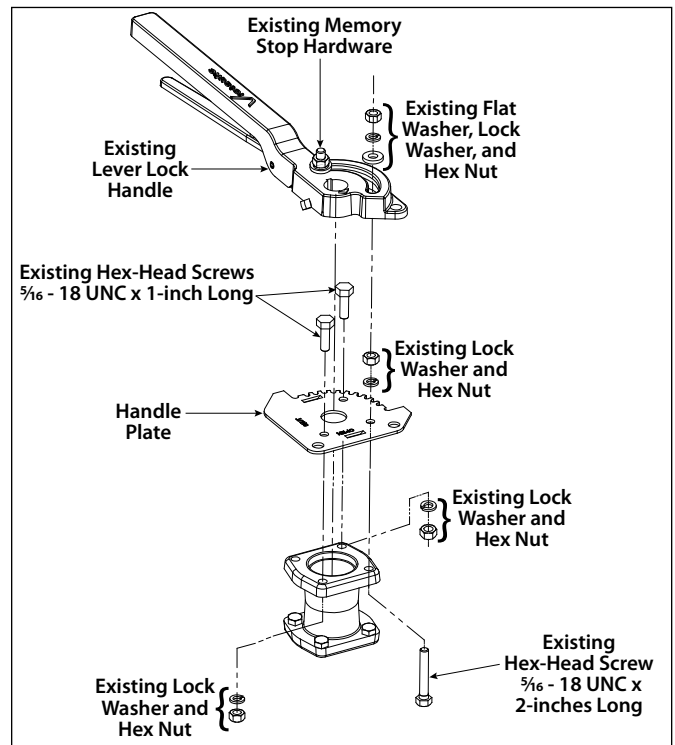

Vic[®]-300 MasterSeal[™] Butterfly Valves

SERIES 761

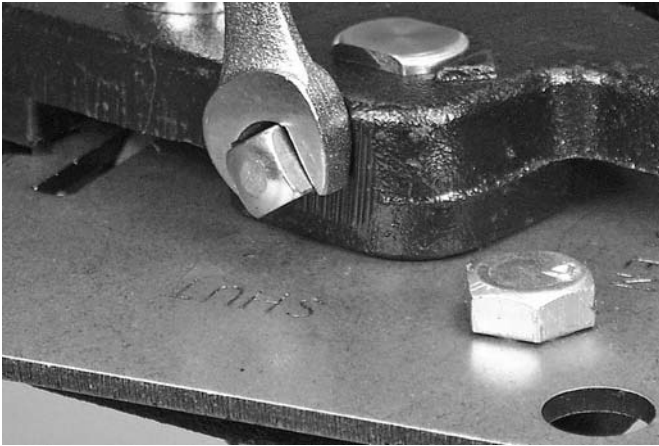

13. Tighten the set screw on the side of the Lever Lock Handle, as shown above.
14. Install the existing flat washer, lock washer, and hex nut onto the $\frac{1}{16}$ - 18 UNC x 2-inch long hex-head screw installed in step 9. Using a wrench, tighten the hex nut until the lock washer becomes flattened.
15. Turn the Lever Lock Handle to ensure proper operation.

Vic[®]-300 MasterSeal[™] Butterfly Valves

SERIES 761



WCAS-7GLN57

For complete contact information, visit www.victaulic.com

I-VIC300MS 3905 REV D UPDATED 08/2008 Z000300MS0

VICTAULIC IS A REGISTERED TRADEMARK OF VICTAULIC COMPANY. © 2008 VICTAULIC COMPANY. ALL RIGHTS RESERVED. PRINTED IN THE USA.

I-VIC300MS

