

VG28GD Cut-Grooving Tool



PARTS ORDERING INFORMATION

When ordering parts, the following information is necessary for Victaulic to process the order promptly:

1. Tool Model Number – VG28GD
2. Tool Serial Number – The Serial Number can be found on the side of the tool.
3. Quantity, Item Number, Part Number, Description
4. Where to send the part(s) – Company Name and Address
5. To whose attention to send the part(s)
6. Purchase Order Number

Parts may be ordered from the nearest Victaulic Sales Office listed on the last page.

VG28GD Cut-Grooving Tool

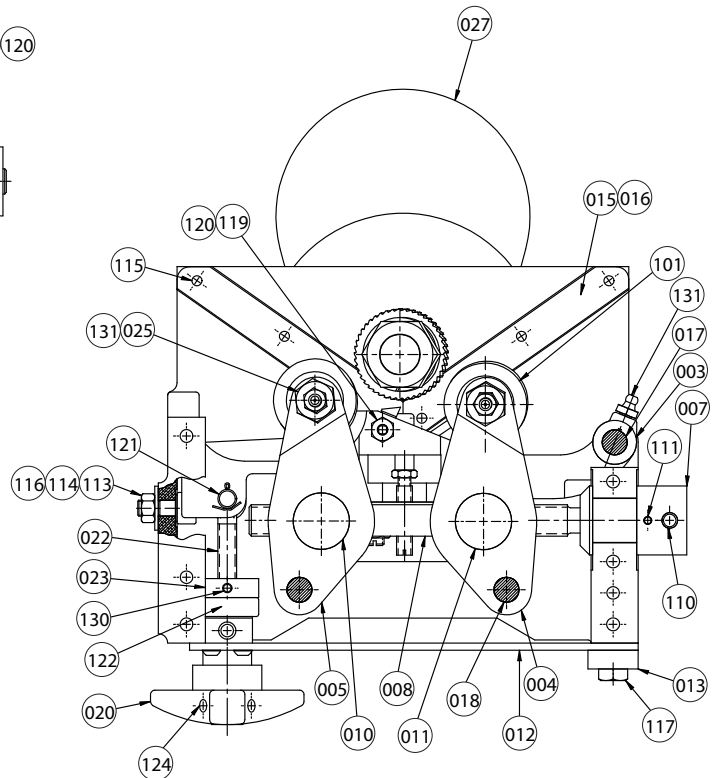
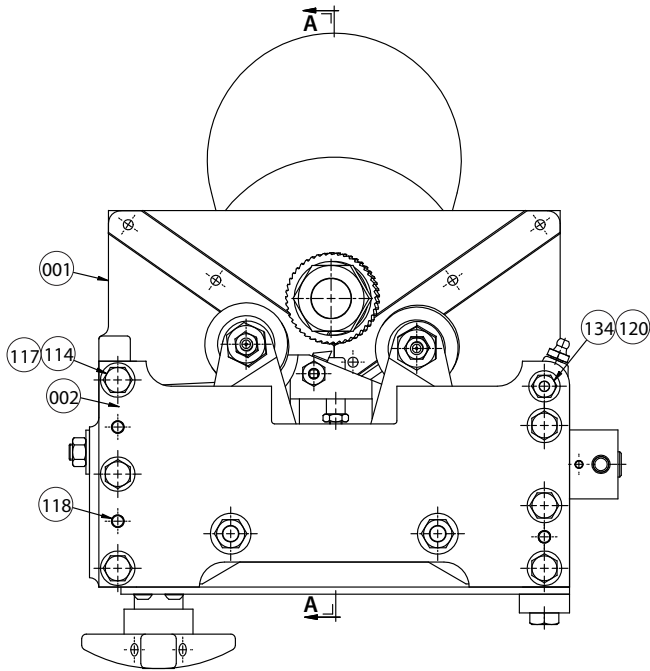

Item#	Part #	Qty.	Description
001	R-001-281-AVG	1	Main Body
002	R-002-280-AVG	1	Front Plate
003	R-003-280-AVG	1	Tool Bit Pivot Arm
004	R-004-280-AVG	1	Right Hand Sup. Roll Swivel Arm
005	R-005-280-AVG	1	Left Hand Sup. Roll Swivel Arm
006	R-006-281-AVG	1	Driven Roll Shaft
007	R-007-280-AVG	1	Collar
008	R-008-2280-AVG	1	Feed Screw
009	R-009-281-AVG	1	Drive Roll
010	R-010-280-AVG	1	Left Barrel Nut
011	R-011-280-AVG	1	Right Barrel Nut
012	R-012-280-AVG	1	Leaf Spring
013	R-013-280-AVG	1	Spring Clamp
014	R-014-280-AVG	2	Trunnion Support
015	R-015-280-AVG	2	End Pipe Stop (Standard)
016	R-016-280-AVG	2	End Pipe Stop (Cast Iron Rigid - Optional)
017	R-017-280-AVG	1	Pivot Stud (Tool Arm)
018	R-018-2280-AVG	2	Pivot Stud (Swivel Arm)
019	R-019-280-AVG	1	Tool Bit Plate
020	R-020-280-AVG	1	Hand Knob
021	R-021-280-AVG	1	Trunnion
022	R-022-280-AVG	1	Eye Bolt

Item#	Part #	Qty.	Description
023	R-023-280-AVG	1	Push Rod Insert
024	R-024-280-AVG	1	Screw Plate
025	R-025-280-AVG	2	Swivel Arm Bearing Stud
026	R-318-824-AVG	1	Tool Bit Back-Up Screw
027	R-028-226-LBL	1	Warning Label - Read All Instructions
028	R-028-280-AVG	1	Extension Handle (Not Shown)
029	R-029-280-AVG	1	Tool Bit Knock-Out Pin (Not Shown)
030	R-312-824-AVG	1	Groove Depth Stop
031	R-412-824-AVG	1	Groove Depth Stop Adj. Screw
032	R-032-281-AVG	1	Wooden Reusable Ship. Container (Not Shown)
033	R-033-281-AVG	1	Drive Roll (Urethane Coated - Optional)
040	R-040-281-AVG	1	Gear Housing
041	R-041-281-AVG	1	Cover
042	R-042-281-AVG	1	Drive Shaft
043	R-043-281-AVG	1	Driving Gear
044	R-044-281-AVG	1	Driven Gear
045	R-045-281-AVG	1	Spacer
101	R-036-280-ASY	2	Bearing Assembly (Support Roll)
109	N-N04-040-000	1	¼ - 28 UNF Hex Jam Nut, Pltd.
110	N-P01-005-400	1	5/16" x 4.00 Lg. Roll Pin
111	N-P80-000-007	1	5/32" x 1.38 Lg. Roll Pin
112	N-S03-010-006	4	10 - 24 UNC x 0.38 Socket Head Cap Screw, Blk. Ox.

VG28GD Cut-Grooving Tool

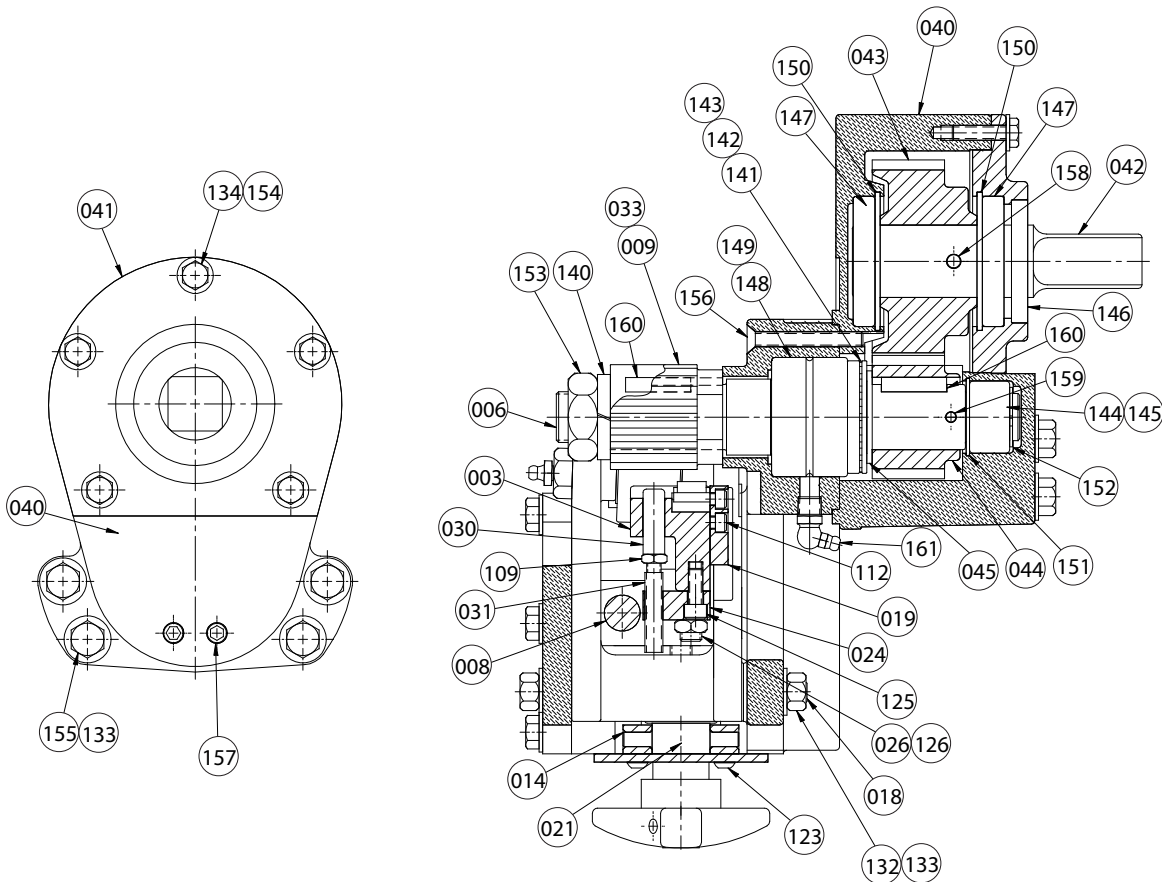

SECTION A-A

Item#	Part #	Qty.	Description
113	N-N02-024-000	1	5/16 - 24 UNF Hex Nut, Pltd.
114	N-W01-050-000	7	3/16" SAE Flat Washer, Pltd.
115	N-S12-040-104	6	1/4 - 20 UNC x 1.25 Slotted Fillister Head Screw, Pltd.
116	N-B06-062-002	1	Cam Follower
117	N-S01-050-104	9	3/16 - 18 UNC x 1.25 Hex Head Cap Screw, Pltd.
118	N-P02-004-100	3	1/4 x 1" Lg. Steel Dowel
119	N-S89-040-108	1	1/4 - 20 UNC x 1.50 Lg. Square Head Set Screw
120	N-N01-040-000	3	1/4 - 20 UNC Hex Nut, Pltd.
121	N-P07-006-103	1	Clevis with Cotter Pin
122	N-B03-062-001	1	Thrust Bearing
123	N-S10-010-006	4	10 - 32 UNF x 0.38 Button Head Cap Screw, Blk. Ox.
124	N-S81-040-006	2	1/4 - 20 UNC x 0.38 Lg. Cup Point Set Screw
125	N-S04-040-010	3	1/4 - 20 UNC x 0.63 Socket Head Cap Screw, Blk. Ox.
126	N-N03-060-000	1	3/8 - 16 UNC Jam Nut, Pltd.
130	N-P01-003-108	1	3/16" x 1.50 Lg. Roll Pin
131	N-M01-000-007	3	Lubrication Fitting
132	N-N01-060-000	4	3/8 - 16 UNC Hex Nut, Pltd.
133	N-W01-060-000	8	3/8" SAE Flat Washer, Pltd.
134	N-W01-040-000	7	1/4" SAE Flat Washer, Pltd.
135	N-M14-000-010	1	3/8 x 7/16" Open End Wrench (Not Shown)
136	N-M14-000-011	1	1/4" Combination Wrench (Not Shown)
140	N-W03-140-000	1	7/8" Lock Washer, Pltd.
141	N-B05-125-002	1	Thrust Washer
142	N-B03-125-001	1	Thrust Bearing
143	N-B05-125-001	1	Thrust Washer
144	N-B02-100-004	1	Bearing

Item#	Part #	Qty.	Description
145	N-B04-081-001	1	Bearing Race
146	N-M27-000-003	1	Oil Seal
147	N-B01-125-001	2	Ball Bearing
148	N-B02-150-001	1	Bearing
149	N-B04-125-002	1	Bearing Race
150	N-T01-000-225	2	Retaining Ring
151	N-T01-000-125	1	Retaining Ring
152	N-T58-000-081	1	Retaining Ring
153	N-N02-140-000	1	7/8 - 14 UNF Hex Nut, Pltd.
154	N-S01-040-100	5	1/4 - 20 UNC x 1.00 Hex Head Cap Screw, Pltd.
155	N-S02-060-108	4	3/8 - 16 UNC x 1.50 Hex Head Cap Screw, Pltd.
156	N-S18-070-200	1	1/4 - 20 UNC x 2.0 Flat Head Socket Cap Screw, Blk. Ox.
157	N-S94-070-005	2	7/16 - 14 UNC x 0.50 Lg. Cup Pt. Socket Seet Screw
158	N-P01-004-204	1	1/4" x 2.25 Lg. Roll Pin
159	N-P01-003-108	1	3/16" x 1.50 Lg. Roll Pin
160	N-K02-040-102	2	1/4" Sq. x 1.13 Lg. Key Round Ends
161	N-M01-000-001	1	Lub. Fitting

Tool Bits

Part Number	Description
R-K02-280-003	2 - 3 1/2" Std. Tool Bit
R-K04-280-006	4 - 6" Std. Tool Bit
R-K08-280-006	8" Std. Tool Bit
R-K03-280-E06	3 - 6" Cast Iron Flexible Tool Bit
R-K03-280-G06	3 - 6" Cast Iron Rigid Tool Bit

VG28GD Cut-Grooving Tool

For complete contact information, visit www.victaulic.com

RP-VG28GD 0181 REV B UPDATED 10/2007 RP00028GD0

VICTAULIC IS A REGISTERED TRADEMARK OF VICTAULIC COMPANY. © 2007 VICTAULIC COMPANY. ALL RIGHTS RESERVED. PRINTED IN THE USA.

RP-VG28GD

