

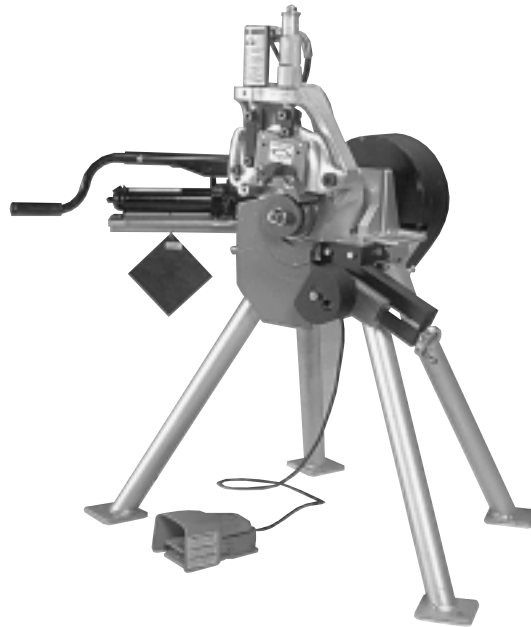

Operating and Maintenance Instructions Manual

VE270FSD Pipe Roll Grooving Tool



! WARNING



- Failure to follow Instructions and warnings can result in serious personal injury.
- Before installing, operating or servicing the VE270FSD tool, read this Manual and all warning labels on the tool.
 - Always wear safety glasses and foot protection.

If you need additional copies of the manual or have any questions about the safe operation of this tool, contact Victaulic Tool Company, P.O. Box 31, Easton, PA 18044-0031, Phone: 610-559-3300.

VE270FSD

INDEX

Hazard Identification	2	Maintenance	21
Operator Safety Instructions	3	General	21
General	3	Lubrication	21
Tool Setup	3	Hydraulic Systems	22
Operating Tool	3	Parts Ordering Information	23
Tool Maintenance	3	Accessories	24
Introduction	4	Victaulic Adjustable Pipe Stands	24
Power Requirements	4	Stabilizer Assembly	24
Extension Cord Requirements	4	Optional Rolls	24
Tool Nomenclature	5	Troubleshooting	25
Receiving Tool	6	Tool Rating and Roll Selection	27
Container Contents	6	Standard and "ES" Rolls	27
Tool Setup	6	Rolls for Stainless Steel (RX Rolls)	28
Pre-Operation Adjustments	7	Rolls for Copper Tubing	28
Grooving Rolls	7	Roll Groove Specifications	29
Pipe Preparation	7	Steel Pipe and All Materials Grooved	
Groovable Pipe Lengths	7	with Standard and RX Rolls	29
Roll Guard Adjustment	9	Drawn Copper Tubing	31
Pipe Stabilizer Adjustment	11	Steel Pipe and All Materials Grooved	
Groove Diameter Stop Adjustment	12	with "ES" Rolls	32
Grooving Operation	14	Dimensions	33
Roll Changing	16	Seamless and Welded Steel Pipe	33
		Drawn Copper Tubing	33

Read this First – Hazard Identification

Definitions for identifying the various hazard levels shown on warning labels or to indicate proper safety procedures in this Manual are provided below.



This safety alert symbol indicates important safety messages on warning labels and in this manual. When you see this symbol be alert to the possibility of personal injury and carefully read and fully understand the message that follows.

! DANGER

The use of the word "DANGER" always signifies an immediate hazard with a likelihood of serious personal injury or death if instructions, including recommended precautions, are not followed.

! WARNING

The use of the word "WARNING" signifies the presence of hazards or unsafe practices which could result in serious personal injury or death if instructions, including recommended precautions, are not followed.

! CAUTION

The use of the word "CAUTION" signifies possible hazards or unsafe practices which could result in personal injury, product or property damage if instructions, including precautions, are not followed.

NOTICE

The use of the word "NOTICE" signifies special instructions which are important but not related to hazards.

VE270FSD

OPERATOR SAFETY INSTRUCTIONS

This tool is designed only for roll grooving pipe. To accomplish this function requires some dexterity and mechanical skills, as well as sound safety habits. Although this tool is manufactured for safe dependable operation, it is impossible to anticipate those combinations of circumstances which could result in an accident. The following instructions are recommended for safe operation of the tool. The operator is cautioned to always practice "Safety First" during each phase of use, including setup and maintenance of this unit. **It is the responsibility of the owner, lessee or user to ensure that all operators receive, read and understand this manual and are fully trained to operate this tool.**

GENERAL

- 1. Read and understand this Manual before operating or performing maintenance on this tool.** Become familiar with the tool's operations, applications and limitations. Be particularly aware of its specific hazards. Store this manual in a clean area and always at a readily available location. Additional copies at no charge are available upon request by writing or phoning the Victaulic Tool Company.
- 2. Use only recommended accessories.** Use of improper accessories may be hazardous. See Accessories on page 24.
- 3. This tool is designed ONLY for roll grooving of pipe sizes, materials and wall thicknesses outlined under Tool Rating and Roll Selection, pages 27 and 28.**

TOOL SETUP

- 1. Ground the drive motor.** Be sure the drive motor is connected to an internally grounded electrical system.
- 2. Avoid dangerous environments.** Don't use the machine in damp or wet locations. Don't use the tool on sloped or uneven ground or floor. Keep work area well illuminated. Allow sufficient space to operate tool and accessories properly and for others to pass safely.
- 3. Prevent back injury.** During tool setup, a lift must be used to handle and position tool.

OPERATING TOOL

- 1. Inspect the equipment.** Prior to starting the tool, check the movable parts for any obstructions. Be sure that guards and tool parts are properly installed and adjusted.
- 2. Prevent accidental startings.**
- 3. Operate with foot switch only.** The VE270FSD must be operated with a safety foot switch, located for easy operator access. The switch should always be accessible to the operator.
- 4. Keep hands away from grooving rolls and stabilizer wheel during grooving operation.** Grooving rolls can crush or cut fingers and hands.
- 5. Never reach inside pipe ends during operation.**
- 6. Do not over-reach.** Keep your proper footing and balance at all times. Be sure you can reach foot switch safely at all times. Do not reach across tool or pipe. Keep hands and loose tools away from moving parts.
- 7. Wear safety glasses and footwear.**
- 8. Keep work area clean.** Cluttered areas, benches and slippery floors invite accidents.
- 9. Wear ear protection if exposed to long periods of very noisy shop operations.**
- 10. Keep visitors away.** All visitors should be kept a safe distance from the work area.
- 11. Keep alert.** Do not operate tool if ill or drowsy from medication or fatigue. Avoid horseplay around tool and keep bystanders a safe distance from tool and pipe being grooved.
- 12. Wear proper apparel.** Never wear loose clothing (unbuttoned jackets or loose sleeve cuffs) loose gloves or jewelry that can get caught in moving parts.
- 13. Do not force tool.** It will do the job better and safer at the rate for which it was designed.
- 14. Secure work, tool and accessories.** Make sure tool is stable. See "Tool Setup" for securing to floor or platform.
- 15. Support work.** Support long pipe with a pipe stand secured to the floor or ground.
- 16. Do not misuse tool.** Perform only the functions for which the tool is designed. Do not overload the tool.

TOOL MAINTENANCE

- 1. Unplug power cord prior to servicing.** Repair should be attempted only by authorized personnel. Always unplug the tool before servicing.
- 2. Maintain tool in top condition.** Keep tool clean for best and safest performance. Follow lubricating instructions.
- 3. Use only genuine Victaulic replacement parts to ensure proper and safe function of the tool.**

VE270FSD

NOTICE

Drawings and/or pictures in this manual may be exaggerated for clarity.

INTRODUCTION

All Victaulic Vic-Easy® Series 270FSD tools are semi-automated hydraulic feed tools for roll grooving of pipe to prepare it to receive Victaulic grooved pipe couplings. The VE270FSD is a completely self-contained unit with a gear motor, safety foot switch and power cord/plug. The VE270FSD is designed to roll groove pipe of various materials and wall thicknesses (see Tool Rating and Roll Selection charts on pages 27 and 28.)

This tool and manual contains trademarks, copyrights and/or patented features which are the exclusive property of Victaulic Company of America.

CAUTION

- This tool should be used only for roll grooving pipe designated in the Tool Rating and Roll Selection charts on pages 27 and 28.
- Use of the tool for other purposes or exceeding the pipe thickness maximums will overload the tool, shorten tool life and may cause tool damage.

POWER REQUIREMENTS

Power must be supplied through a safety foot switch to ensure safe operation. Be sure the tool is properly grounded in accordance with Article 250 of the National Electrical Code. If an extension cord is to be used, see Extension Cord Requirements for cord size recommendations.

DANGER



- To reduce the risk of electric shock, check the electrical source for proper grounding and follow the instructions below.
- Before performing any repair or maintenance, disconnect the tool from the electrical source. Failure to do so could result in death or serious personal injury.

EXTENSION CORD REQUIREMENTS

When pre-wired outlets are not available and an extension cord must be used, it is important to use the proper cord size (e.g., conductor size American Wire gauge). Cord size selection is based upon tool rating (amps) and cord length (feet). Use of a cord size (gauge) thinner than required will cause a significant voltage drop at the gear motor while the tool is operating. The voltage drop may cause damage to the gear motor and can result in failure of the tool to operate properly. Use of a heavier than necessary cord size (gauge) is acceptable.

Listed in the chart below are recommended cord size (gauge) for cord lengths up to and including 100 feet. Use of extension cords beyond 100 feet in length should be avoided.

Tool	Tool Rating Volt/Amps	Cord Lengths		
		25'	50'	100'
VE270FSD	115/15	12	12	10

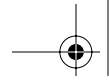

VE270FSD

TOOL NOMENCLATURE

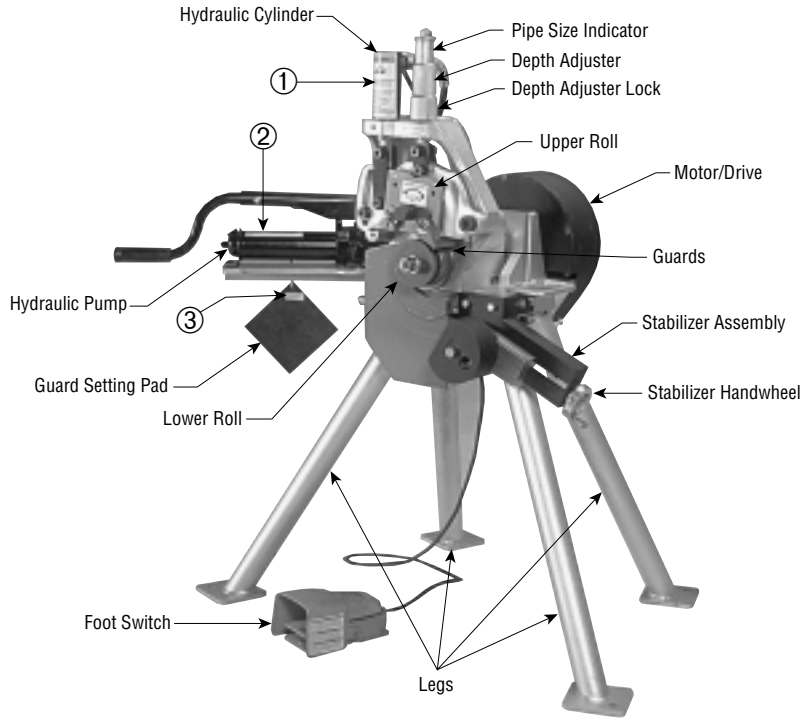

③

ALWAYS KEEP THIS PAD WITH THE TOOL. USE IT TO SET THE GUARDS IN ACCORDANCE WITH THE TOOL OPERATION AND MAINTENANCE MANUAL.

R068272LAB

②

⚠ WARNING	
	<p>Failure to follow instructions and warnings can result in serious injury, property damage, or faulty installation.</p> <ul style="list-style-type: none"> • Before installing, operating, or servicing this tool, read and understand the Operating Instructions and all warning labels on this tool. • Always wear safety glasses and foot protection. <p><small>If you have any questions about the safe operation of this tool, contact Victaulic Tool Company, P.O. Box 31, Easton, PA 18044-0031, 610-559-3300.</small></p>

0567 Rev.A

R031272LAB 3/99

①

⚠ WARNING	
<p>Grooving rolls can crush or cut fingers and hands.</p> <ul style="list-style-type: none"> • Always unplug the power cord before adjusting guard. • Be sure guard is properly adjusted before grooving pipe. • Keep hands away from grooving rolls and stabilizer wheel. • Never reach inside pipe end or across the tool or pipe during operation. • Never groove pipe shorter than what is recommended. • Never wear loose clothing, loose gloves or jewelry while operating tool. 	

2244 Rev.B 3/98

R007276LBL

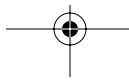

VE270FSD

RECEIVING TOOL

VE270FSD tools are palletized individually and covered with a cardboard sleeve designed for use in re-shipping tools.

NOTE: Be sure to save original shipping container for return shipment of rental tools.

VE270FSD CONTAINER CONTENTS

Upon receipt of tool, make sure all necessary parts are included. If any parts are missing, notify your Victaulic distributor or Victaulic representative.



1. Tool head with mounting table and gear motor, (4) legs and foot switch with cord and pump/pump support assembly.
2. Rolls for 1 - 1½", 2 - 3½", 4 - 6" and 8 - 12" steel pipe. The 8 - 12" rolls are mounted on the head assembly.
3. Two (2) VE270FSD Operating and Maintenance Instructions Manuals.
4. Guard setting pad.
5. Lower roller removal wedge.
6. Stabilizer with mounting hardware, if ordered.
7. Spare Woodruff keys.
8. One (1) 11 oz. can of Dow Corning G-n Mechanical Assembly Spray.

The standard Series VE270FSD tools are supplied with grooving rolls for 1 - 12" carbon steel pipe. Rolls are marked with the size and part number and color coded for pipe material, for your convenience. For grooving to other specifications and other materials, see Tool Rating and Roll Selection charts on pages 27 and 28. Grooving rolls for other specifications, sizes and other materials must be purchased separately.

TOOL SETUP

⚠ WARNING

- Do not plug in tool until instructed otherwise. Accidental start up of tool may result in serious personal injury.

1. Remove all components and check to be sure all necessary items are included. See list under Receiving Tool.
2. Select location for tool and pipe stand. Choose a location that has:
 - a. The required power. Consult Power Requirements on page 4.
 - b. The space necessary to adequately handle the pipe to be grooved.
 - c. A level and even surface for tool, pipe stand and footing.

⚠ WARNING

- During tool setup, one person cannot safely handle the tool because it weighs 375 lbs. If a hoist is available, use it to lift the tool head assembly into position. Failure to follow this instruction may result in serious personal injury.

3. Place tool on level floor or platform. Using holes provided in feet, secure tool to the platform or floor. The tool's legs are adjustable in length to compensate for uneven surfaces. Adjust as necessary to maintain tool levelness.



4. Level the tool front to back. The top of the hydraulic ram is a good location to measure "level".

VE270FSD

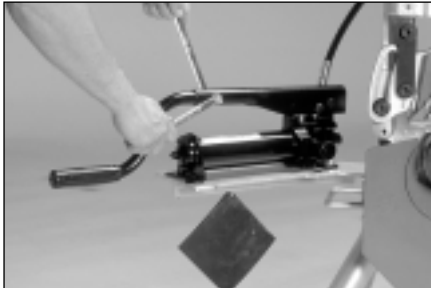

5. Insert the hand pump handle into lever arm of the pump. Position handle with handle grip down. Lock handle in this position with set screw or nut and bolt provided.



6. Connect the hydraulic line from the pump to the power cylinder using connectors provided.

VE270FSD tool setup is complete.

PRE-OPERATION ADJUSTMENTS

Every Vic-Easy tool is checked, adjusted and tested at the factory prior to shipment. Before grooving, however, the following adjustments must be made in sequence to make sure of proper tool operation.

! WARNING

- Always unplug power cord before making any tool adjustments, unless instructed otherwise.
- Accidental start up of tool may result in serious personal injury.

GROOVING ROLLS

Make sure the proper roll set is on the tool for the pipe size and material to be grooved. They are marked with the pipe size, part number and color coded for the pipe material to be grooved. See Tool Rating and Roll Selection charts on pages 26 and 27. If proper rolls are not on tool, refer to Roll Changing on page 16.

! CAUTION

- Make sure roll retaining bolts and nuts are tight. Loose retaining bolts or nuts could seriously damage both the tool and rolls.

PIPE PREPARATION

For proper tool operation, and production of proper pipe grooves, carefully observe the following pipe preparation tips.

1. Pipe ends should be cut squarely in accordance with Column 2 note on appropriate Roll Groove Specification chart, pages 29 - 32.
2. Internal or external weld bead or seams must be ground flush with the pipe surface extending 2" back from the pipe end.
3. The end of the pipe, both inside and out, must be cleaned of loose rust, coarse scale, dirt and other foreign material.

! CAUTION

- For maximum grooving roll life, remove foreign material and loose rust.
- Foreign material such as coarse scale or dirt might interfere with or damage the grooving rolls or distort the groove. Rust is an abrasive material and will tend to wear out the surface of grooving rolls.

4. Victaulic recommends that pipe shall be square ended. When using beveled pipe, standard wall or less, the bevel should not exceed 37½°. Square ended pipe must be used with FlushSeal® and EndSeal® gaskets. For heavier pipe walls, square ended pipe is required.

GROOVABLE PIPE LENGTHS

The VE270FSD is capable of grooving short pipe lengths without the use of a pipe stand (see Table 1 on page 8), or long pipe lengths up to double randoms (approximately 40 ft.), with the use of appropriate stands.

VE270FSD

SHORT PIPE LENGTHS

Table 1 shows minimum and maximum pipe lengths that can be grooved hands-off without the need for a pipe stand. You do not have to manually guide the pipe while grooving. For pipe longer than shown in Table 1, refer to Long Pipe Lengths at right.

WARNING



Grooving rolls can crush or cut fingers and hands.

- Loading and unloading pipe will place your hands close to the rollers.
- Never groove pipe shorter than what is recommended in Table 1 below.

TABLE 1
VE270FSD GROOVABLE PIPE LENGTHS

2468-1A

DIMENSIONS – (Inches/mm)					
Nom. Size	Min. Length	Max. Length	Nom. Size	Min. Length	Max. Length
¾	8	36	4½	8	32
20	203.2	914.4	115	203.2	812.8
1	8	36	5	8	32
25	203.2	914.4	125	203.2	812.8
1¼	8	36	6 O.D.	10	30
32	203.2	914.4	150	254.0	762.0
1½	8	36	6	10	28
40	203.2	914.4	150	254.0	711.2
2	8	36	8 O.D.	10	24
50	203.2	914.4	200	254.0	609.6
2½	8	36	8	10	24
65	203.2	914.4	200	254.0	609.6
3	8	36	10	10	20
80	203.2	914.4	250	254.0	508.0
3½	8	36	12	12	18
90	203.2	914.4	300	304.8	457.2
4	8	36			
100	203.2	914.4			

If a pipe shorter than the minimum shown in Table 1 is needed, if possible, shorten the next to last piece of pipe enough so that the last piece of pipe is as long or longer than the minimum length specified in Table 1. See example at right.

NOTICE

Pipe nipples shorter than those shown in Table 1 are available from Victaulic.

Example: A 20' 4" length of 10" diameter pipe is needed to finish a section and you only have 20' lengths available. Instead of roll grooving a 20' piece of pipe and a 4" piece of pipe, follow these steps:

1. Refer to Table 1 and note that for 10" diameter pipe, the minimum length that should be grooved is 10".
2. Roll groove a 19' 6" piece of pipe and a 10" piece of pipe. Refer to Long Pipe Lengths below.

LONG PIPE LENGTHS

With pipe in excess of the maximum length shown in Table 1, a roller type pipe stand must be used.

NOTICE

Figure 1 shows the Victaulic adjustable pipe stand (VAPS 112). VAPS 112 is suitable for ¾" to 12" pipe. Also available is Victaulic model VAPS 224 suitable for sizes 2" to 24". See Accessories on page 24.

1. Position pipe and pipe stand in accordance with Figures 1 and 2.

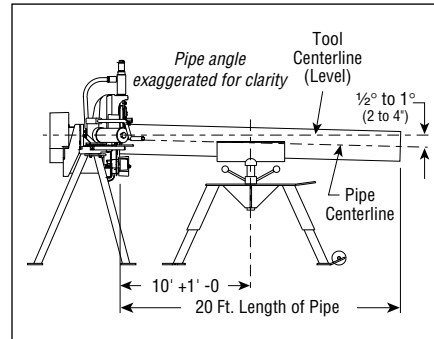

SUPPORT OF PIPE
Figure 1

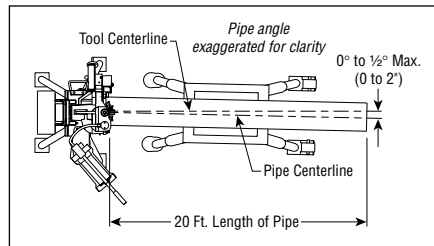

TRACKING ANGLE
Figure 2

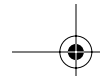

VE270FSD

! WARNING

- Pipe stand location will affect pipe tracking.
- Incorrect pipe stand position may result in pipe being pushed out of rolls and falling.

Failure to position pipe and pipe stand in accordance with Figures 1 and 2 (shown on page 8) may result in serious personal injury or property damage.

! CAUTION

Pipe position will affect pipe flare.

- When pipe end flare is excessive, right-to-left tracking must be kept to a minimum. It may be necessary to use less than ½ degree.

Make sure tool is level (see Tool Setup).

- If pipe is grooved with back end of pipe (end of pipe which is not in tool) higher than the end being grooved, pipe may not track and excessive pipe end flare may result.
- Assembly of couplings on pipe exceeding Maximum Allowable Flare, Column 8 in the Roll Groove Specifications charts, pages 29 - 32, may prevent closure of couplings pad-to-pad, allowing possible pipe separation, and result in property damage.
- Also, joint leakage may result due to excessive gasket distortion/damage.

NOTICE

For additional information about pipe stands, refer to the Operating Instructions included with your pipe stand.

ROLL GUARD ADJUSTMENT

The VE270FSD guards must be adjusted every time rolls are changed or pipe size or wall thickness is different from previous pipe grooved.

! WARNING

- Always unplug the power cord before making any roll guard adjustments.

Accidental start up of tool may result in serious personal injury.



1. Make sure the proper roll set is on the tool for the pipe size and material to be grooved. Rolls are marked with the pipe size, part number and are color coded for pipe material for your convenience. See Tool Rating and Roll Selection charts pages 27 and 28. If the proper rolls are not on the tool, refer to Roll Changing on page 16.



2. Loosen wing nuts and move the adjustable guards to the full up position. Tighten wing nuts.



3. Set groove diameter stop to pipe size and schedule/thickness to be grooved. To do this, back off the depth adjuster lock, align the depth adjuster with the proper diameter and thickness. Lock the depth adjuster in position with the depth adjuster lock.

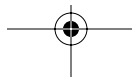

VE270FSD

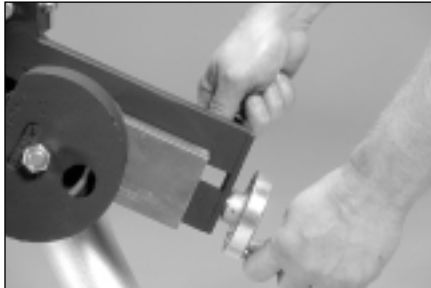

4. If so equipped, retract stabilizer, if necessary, to insert pipe. To do this, loosen locking handle and retract stabilizer roller with the hand wheel to clear pipe when inserted onto lower roll.

! WARNING

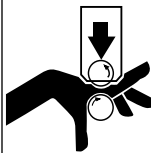

Grooving rolls can crush or cut fingers and hands.

- Loading and unloading pipe will place your hands close to the rollers.
- Never groove pipe shorter than what is recommended in Table 1 on page 8.



5. Insert a piece of pipe of the correct size and schedule/thickness to be grooved over the lower roll with the pipe end against the lower roll backstop flange. See Pipe Preparation on page 7.



6. Close hand pump valve.



7. Pump upper roll down into firm contact with pipe.



8. Remove the guard setting pad from its storage hook beneath the pump support. Hold the guard setting pad firmly down against the pipe and push it under the adjustable guards flush against the red plate.

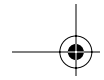

VE270FSD



9. Loosen the wing nuts and adjust each guard to conform to and lightly pinch the pad against the pipe. Tighten wing nuts to secure guards in position.

10. Remove the guard setting pad. Store the pad back on the hook provided under pump base.

PIPE STABILIZER ADJUSTMENT

(Applies only to tools equipped with the optional stabilizer.)

The Series VE270FSD Pipe Stabilizer (Optional) is designed to prevent pipe sway on 8" through 12" nominal IPS pipe sizes. This applies to short as well as long pipes. Once the stabilizer is adjusted for a selected pipe size and wall thickness, it does not require further adjustment on that size and thickness. Pipe of the same size and thickness may be moved in and out of the tool without retracting stabilizer.

⚠ WARNING

- **Unplug power cord until instructed otherwise.**
- Accidental start up of tool may result in serious personal injury.**

1. Make sure proper roll set is on the tool for the pipe size and material to be grooved. Rolls are marked with pipe size, part number and are color coded for pipe material for your convenience. See Tool Rating and Roll Selection charts on pages 27 and 28.

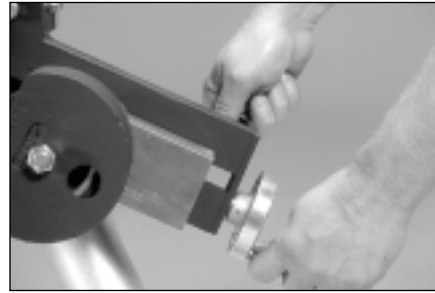

2. Loosen locking handle. With the hand wheel, retract stabilizer roller to clear pipe when inserted onto lower roll.

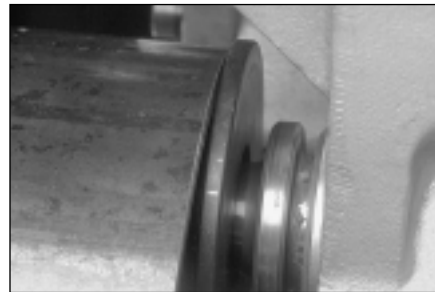

3. Insert a piece of pipe of the correct size and schedule to be grooved over the lower roll with the pipe end against the lower roll backstop flange.



4. Close hand pump valve and pump upper roll down into firm contact with pipe.

5. Make sure guards are properly adjusted per the Roll Guard Adjustment Procedure, page 9.

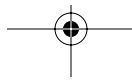

VE270FSD

6. Advance stabilizer roller inward with hand-wheel to the position indicated in Figure 3 below, then tighten locking handle.

CAUTION

Do not adjust stabilizer to push pipe to the left and off center from the rolls (see Figure 4 at right). Doing so will cause increased pipe end flare and shorten roller life.

- Assembly of couplings on pipe exceeding Maximum Allowable Flare, Column 8 in the Roll Groove Specifications charts, pages 29 - 32, may prevent closure of couplings pad-to-pad, allowing possible pipe separation and result in property damage.
- Also, joint leakage may result due to excessive gasket distortion/damage.

7. Complete the **Pre-Operation Adjustments** and groove the pipe (see Grooving Operation pages 14 - 16.) Observe the stabilizer roller while grooving. It should remain in contact with the pipe most of the time and the pipe should rotate smoothly without swaying from side to side. If not, advance stabilizer roller further inward. Retest and make further adjustments as necessary. Remember, do not adjust stabilizer too far inward as it will skew the pipe to the left and possibly result in excessive pipe end flaring.

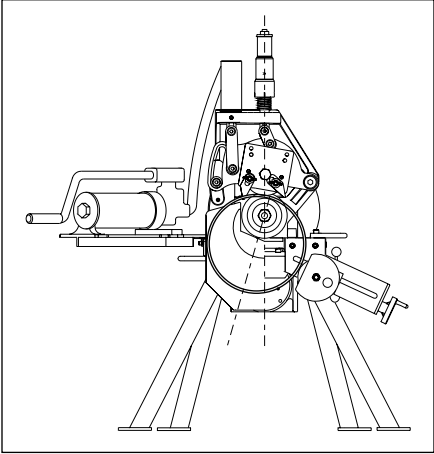

"INCORRECT"
Figure 4

GROOVE DIAMETER STOP ADJUSTMENT

The groove diameter stop must be adjusted for each pipe size or change in wall thickness. Groove diameter, identified as the "C" dimension for each pipe size, is listed under Roll Groove Specifications, pages 29 - 32. For your convenience, a "C" Diameter Chart for Steel Pipe is also on the tool.

NOTICE

To perform the following adjustments, use several short scrap sections of pipe (but not shorter than what is recommended in Table 1, page 8) of the proper material, diameter and thickness to be grooved.

- To achieve proper diameter:**
1. Determine the diameter and thickness of the pipe to be grooved. (See the Dimensions Charts on page 33.)
 2. Locate the proper diameter and thickness on the pipe size indicator on the depth stop. It is rotatable for easy viewing.

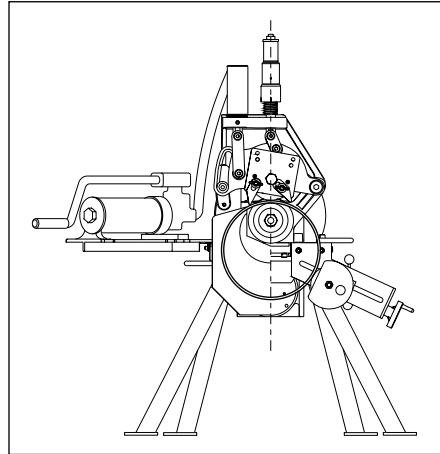

"CORRECT"
Figure 3

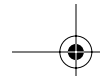

VE270FSD



3. Back off the depth adjuster lock. Align the depth adjuster with the proper diameter and thickness as shown. Lock the depth adjuster in position with the depth adjuster lock.

NOTICE

The markings provide an approximate groove diameter adjustment and are not exact groove diameter settings. Variations in actual pipe O.D.'s and wall thicknesses make it impossible to calibrate the diameter stop exactly.



4. Insert the pipe over the lower roll with the pipe end against the lower roll back stop flange.

WARNING

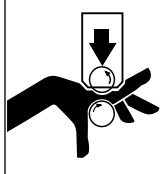

Grooving rolls can crush or cut fingers and hands.

- Always unplug the power cord before adjusting guard.
- Be sure guard is properly adjusted before grooving pipe.
- Keep hands away from grooving rolls and stabilizer wheel.
- Never reach inside pipe end or across the tool or pipe during operation.
- Never groove pipe shorter than what is recommended.
- Never wear loose clothing, loose gloves, or jewelry while operating tool.

5. Prepare a trial groove. To do so, follow the Grooving Operation Procedures outlined on pages 14 - 16.



6. After a trial groove is prepared and the pipe is removed from the tool, carefully check the groove diameter ("C" dimension), as charted on pages 29 - 32 under Roll Groove Specifications. The "C" dimension is best checked with a Pi tape. It may also be checked with a vernier caliper or narrow land micrometer at two locations, 90 degrees apart, around the groove. The average reading must be within the required groove diameter specification.

CAUTION

- The "C" dimension (groove diameter) must always conform to specifications under Roll Groove Specifications pages 29 - 32 to ensure proper joint performance.

Failure to do so could result in personal injury, property damage, improper installation, joint leakage or joint failure.

7. If groove diameter ("C" dimension) is not within tolerance, the diameter stop must be adjusted to obtain the proper dimension. To adjust for a **smaller groove diameter**, turn the depth adjuster and depth adjuster lock **counterclockwise**. To adjust for a **bigger groove diameter**, turn the depth adjuster and depth adjuster lock **clockwise**. A quarter turn either way will change the groove diameter adjustment by **0.031"** (0.125" per full turn).

8. Prepare another trial groove and check the groove diameter again. Repeat steps 6 and 7 until the groove diameter is within specification.

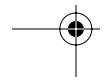
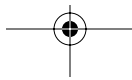

VE270FSD

GROOVING OPERATION

CAUTION

- Vic-Easy Series VE270FSD tools are designed **ONLY** for roll grooving pipe of the sizes, materials and wall thicknesses outlined under Tool Rating and Roll Selection charts on pages 27 and 28.

Grooving pipe other than that recommended will result in improper pipe end configuration or improper groove dimensions for applying Victaulic products.

Before grooving, make sure you have followed all instructions in:

- "Tool Setup" on page 3
- "Grooving Rolls" on page 7
- "Pipe Preparation" on page 7
- "Groovable Pipe Lengths" on page 7
- "Roll Guard Adjustment" on page 9
- "Pipe Stabilizer Adjustment" on page 11
- "Groove Diameter Stop Adjustment" on page 12

WARNING



- Before operating tool, review all safety precautions on page 3. Failure to do so may result in serious personal injury.

DANGER



- To reduce the risk of electric shock, check the electrical source for proper grounding and follow the instructions below. Failure to do so could result in death or serious personal injury.

1. Plug the VE270FSD into an internally grounded electrical source. Make sure motor is grounded.

2. Actuate safety foot switch by pressing foot on pedal to be certain tool is operational, power supply is available, and that lower roll is turning clockwise when viewed from the front. Remove foot from foot switch.



3. Open hydraulic pump pressure release valve by turning counterclockwise. This will allow upper roll and arm to move to full up position.

WARNING

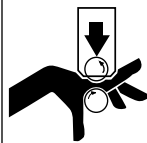

Grooving rolls can crush or cut fingers and hands.

- Always unplug the power cord before adjusting guard.
- Be sure guard is properly adjusted before grooving pipe.

- Keep hands away from grooving rolls and stabilizer wheel.
- Never reach inside pipe end or across the tool or pipe during operation.
- Never groove pipe shorter than what is recommended.
- Never wear loose clothing, loose gloves, or jewelry while operating tool.

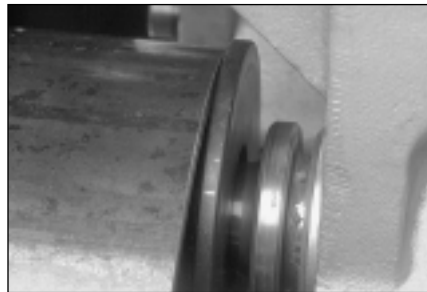

4. Insert a piece of pipe of the correct size and thickness to be grooved, onto the lower roll, with the pipe end squarely against the lower roll back-stop flange. If grooving a pipe supported by a pipe stand, remove hands from pipe.

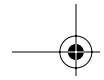

VE270FSD



5. Close the pressure release valve on the pump by turning clockwise.



9. Depress and hold down safety foot switch. The pipe will begin to rotate clockwise. As the pipe rotates, begin grooving by slowly pumping the pump handle.



6. Operator should position himself as shown.

NOTICE

Do not pump too fast, but at a rate sufficient to groove the pipe and maintain audible moderate-to-heavy load on the gear motor.



7. Pump the handle several times to bring the upper roll into light but firm contact with the pipe.

8. If grooving a short pipe (see Table 1, page 8), remove hands from pipe.



10. Continue grooving until the depth stop comes into full, firm contact with top of tool body. Continue pipe rotation for one (1) to three (3) revolutions to assure groove completion.

11. Release safety foot switch and withdraw foot from switch.

! WARNING

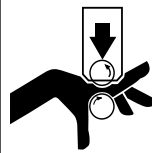

Grooving rolls can crush or cut fingers and hands.

- Do not place hand(s) inside end of pipe to pull pipe out of tool or place hand(s) in area of grooving rolls or stabilizer roller.

12. If grooving a short pipe, manually support pipe.

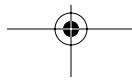

VE270FSD

ROLL REMOVAL PROCEDURE

LOWER ROLL – ¾" & 1 - 1½" SIZES

1. Open hand pump release valve (turn knob counterclockwise) and arm will move to the full open position.



13. Open hydraulic release valve to release pipe. Remove pipe from tool.



2. With a wrench fitted on the square end of lower roll, loosen and remove lower roll as an assembly by turning clockwise. Store lower roll in a clean place.

NOTICE

Groove diameter should be correct for the diameter and wall thickness of pipe for which it was set under Groove Diameter Stop Adjustment. Groove diameter should be checked periodically and adjusted as necessary to assure grooves are within specification

NOTICE

The ¾" and 1 - 1½" lower roll assembly is held in position with left hand threads and must be loosened by turning clockwise.

ROLL CHANGING

⚠ WARNING

- Always unplug power cord before changing rolls. Accidental start up of tool may result in serious personal injury.

Vic-Easy Series 270FSD roll grooving tools are designed for fast, easy grooving. Rolls accommodate several pipe sizes (refer to Tool Rating and Roll Selection charts on pages 27 and 28) eliminating the need for frequent roll changes. When a different size range is encountered or different grooving styles are required, the grooving rolls must be changed and Pre-Operation Adjustments re-performed. Also, different pipe materials may require that the rolls be changed. See Tool Rating and Roll Selection charts on pages 27 and 28 for proper roll selection.

LOWER ROLL – 2" AND LARGER SIZES

1. Open hand pump release valve (turn knob counterclockwise) and arm will move to the full open position.

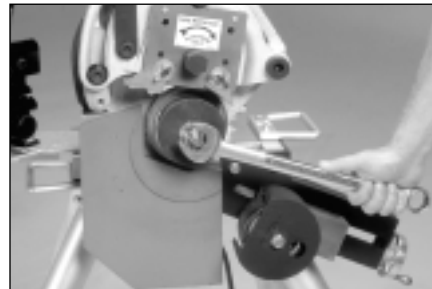

2. With a wrench, loosen and remove (thin) jam nut securing large nut on lower roll shaft.

VE270FSD

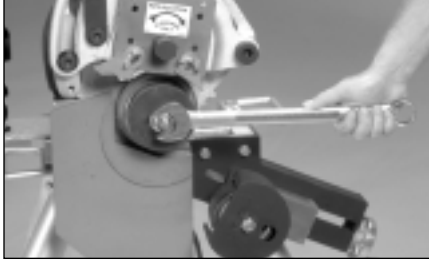

3. With a wrench, loosen large nut on lower shaft and back off approximately 1/4" without removing.

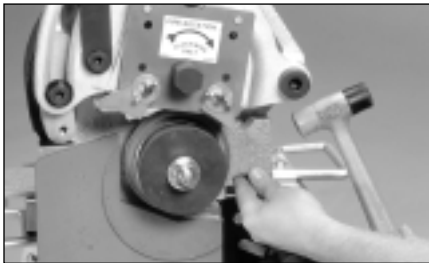

4. To loosen lower roll from tapered lower roll shaft, use the aluminum wedge supplied with tool. Place wedge behind lower roll and hit with a hammer to break roll loose from taper. **Do not use a hammer on the roll.**

⚠ WARNING



Hammering rolls can cause serious personal injury due to fragmentation.

- Always wear eye protection.
- Always use supplied aluminum wedge for roll removal.

- Always use soft faced hammers with aluminum wedge.
- Never strike rolls directly for any reason.



5. Remove nut, washer and roll and store in a clean place.

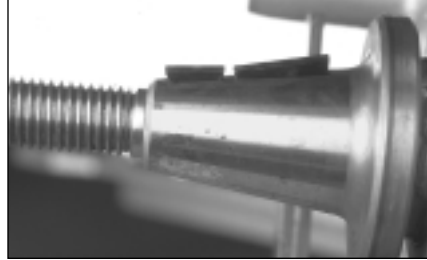

NOTICE

Be careful not to lose the Woodruff keys. They should remain in the 2 - 12" arbor. Inspect the Woodruff keys and replace if damaged. Spare Woodruff keys have been placed in the Instruction Manual.

UPPER ROLL – ALL SIZES

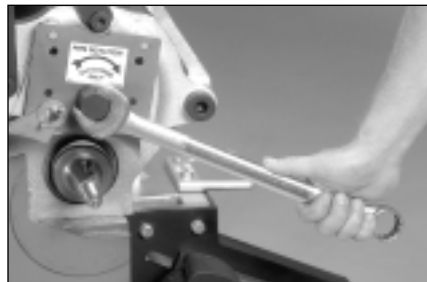

1. With a wrench, loosen and remove upper roll bolt. Place on a clean surface.

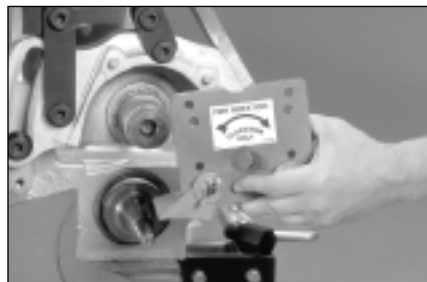

2. Pull the upper roll assembly off. Store in a clean place.

VE270FSD

**ARBOR SHAFT
REMOVAL PROCEDURE**

See Tool Rating and Roll Selection charts on pages 27 and 28 for information on available grooving rolls.

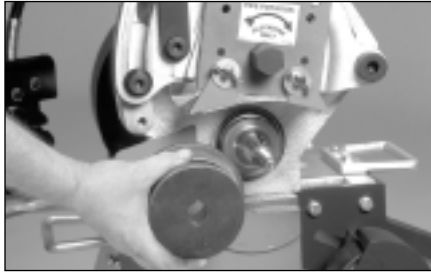

1. Remove roll set from tool. Refer to Roll Removal Procedure for 2" and larger sizes on page 16.



2. With a wrench fitted on exposed hex portion of stud, fully loosen the stud by turning **counterclockwise**. The arbor should move outwards as the stud is loosened.



3. Once the stud has stopped moving the arbor outwards, pull the arbor shaft and stud assembly out and store in a clean place.

NOTICE

In the event of insufficient lubrication, the arbor shaft could become difficult to remove from the main shaft. The arbor shaft features three (3) 1/4" - 20 UNC tapped holes so that jack bolts can be used to push out the arbor shaft.

CAUTION

- Never operate tool with the jack bolts installed in the arbor shaft.
- Failure to follow this instruction may result in personal injury, product or property damage.

**ROLL INSTALLATION
PROCEDURE**

See Rating and Roll Selection Chart on pages 27 and 28 for information on available grooving rolls.

UPPER ROLL – ALL SIZES



1. Clean all shaft surfaces and roll bores of any dirt and/or scale before installation.

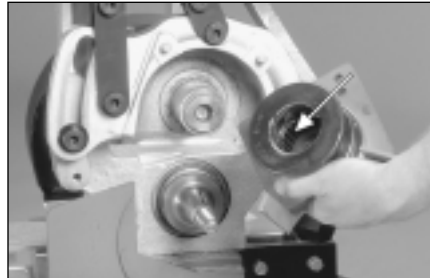

2. While upper roll is removed from tool, inspect the roller bearing inside for contamination, proper lubrication and movement. Also inspect guards for wear and freedom of adjustment. Make repairs/replacements as necessary.

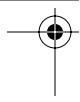
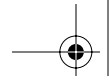

VE270FSD



3. Carefully slide desired upper roll assembly onto upper shaft with red plate facing out. Loosen guards, if necessary, to make installation easier. Make sure red plate engages the two pins on the arm and that it then contacts the front of the upper roll shaft.

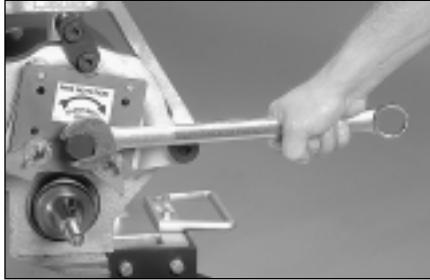

4. Insert upper roll bolt and tighten securely with a wrench.



5. Lubricate upper roll bearing. Refer to Maintenance section for additional information.

LOWER ROLLS – ¾" & 1 - 1½" SIZES



1. Clean the bore of the main shaft and the roll assembly parts with a soft cloth.



2. Lightly lubricate the roll assembly parts with the proper lubricant (Dow Corning G-n mechanical assembly spray, supplied with tool and available from the Victaulic Tool Company.)



3. Carefully insert the lower roll and adapter assembly into the main shaft, making sure it is fully seated. It may be necessary to rotate the adapter to align its square back end with the main shaft. Tighten the lower roll by turning **counterclockwise**.

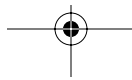
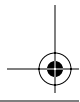

VE270FSD

ARBOR SHAFT INSTALLATION PROCEDURE

2" AND LARGER SIZES



1. Clean the bore of the main shaft and the arbor shaft assembly parts with a soft cloth.



2. Lightly lubricate the arbor shaft parts with the proper lubricant (Dow Corning G-n mechanical assembly spray, supplied with tool and available from the Victaulic Tool Company.)



3. Carefully insert the arbor shaft assembly into the main shaft, making sure it is fully seated. It may be necessary to rotate the adapter to align its square back end with the main shaft. Tighten the remaining stud by turning the exposed hex portion of the stud **clockwise**.

ROLL INSTALLATION PROCEDURE

LOWER ROLL – 2" AND LARGER SIZES

NOTICE

Arbor shaft must be installed prior to installing 2" and larger size lower rolls. See instructions at left.

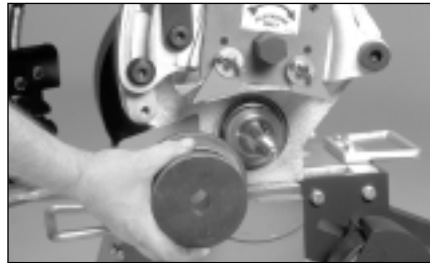

1. Place lower roll onto arbor shaft. Reposition guards, if necessary, to make assembly easier. Make sure lower roll fits fully onto arbor shaft with keys and keyway in alignment.



2. Install flat washer and large nut on threaded arbor stud, in front of lower roll, and tighten securely with a wrench.

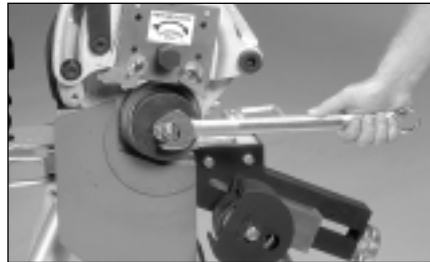

3. Install (thin) jam nut on threaded arbor stud and tighten securely, with a wrench, against large nut.

Roll Installation is complete. Before grooving, make sure all **Pre-Operation Adjustments** are reviewed and followed.

VE270FSD

MAINTENANCE

GENERAL

This manual provides information on keeping tools in top operating condition and guidance in making repairs when it becomes necessary.

Replacement parts, applicable only to these tools, should be ordered from Victaulic to assure proper operation of the tool. All parts are FOB Easton, Pennsylvania, at the price in effect at the time of ordering.

NOTICE

Remember that preventative maintenance during operation will pay for itself in repair and operating savings.

⚠ DANGER



- Before performing any repair or maintenance, unplug the tool from the electrical source to prevent accidental start up of tool.

Failure to do so could result in death or serious personal injury.

LUBRICATION

After every 8 hours of operation lubricate the machine. Always lubricate upper roll bearings when rolls are changed.



1. Grease upper roll bearing at fitting provided as shown with a No. 2EP Lithium base grease.

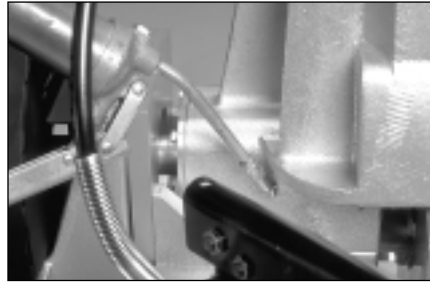

2. Grease main shaft bearings at grease fitting with a No. 2EP Lithium base grease.

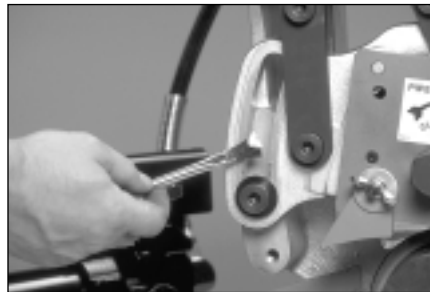

3. Lubricate the linkage mechanisms, the arm pivot point, and the arm sliding surfaces. A heavy duty spray lubricant may be used or apply grease by hand.

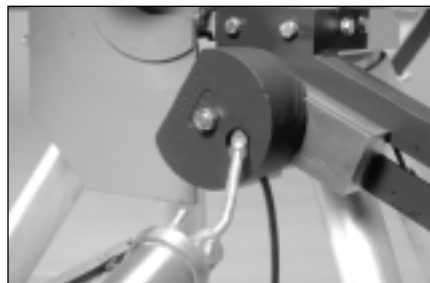

4. Lubricate the optional stabilizer wheel with a No. 2EP Lithium base grease.

VE270FSD

HYDRAULIC SYSTEMS

The level of hydraulic fluid in the pump must be checked semi-annually or if pumping feels spongy.

FILLING AND CHECKING

1. Open pump release valve fully by turning counterclockwise.



2. Remove pump and pump support from tool base.

3. Loosen, but do not remove the hydraulic fill plug/dipstick at the back end of the pump.



4. Hold pump so that fill plug end is ABOVE the hydraulic cylinder. This will prevent siphoning of oil from hydraulic cylinder through pump.

5. Check fluid level. Add hydraulic jack oil to proper level as required. On models without dipstick, remove cap; oil should be approximately 1/2" to 1" from the end.

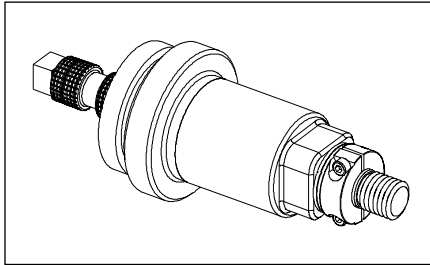

5. After every 40 hours of operation, clean and lubricate the 3/4" and 1 - 1/2" lower roll sets.

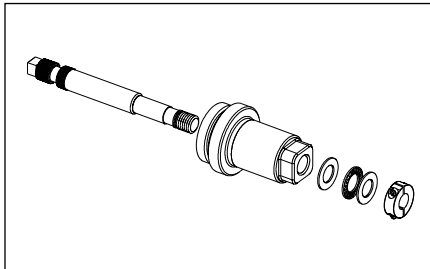

6. Remove the cap screws and disassemble the two-piece collar. Remove both the collar and needle bearing and washers.

7. Remove lower roll from arbor. Clean the 3/4" and 1 - 1/2" lower roll and lightly lubricate with the proper lubricant (Dow Corning G-n mechanical assembly spray, supplied with tool and available from Victaulic Tool Company.)

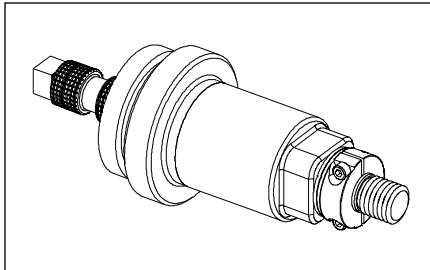

8. Reassemble the 3/4" and 1 - 1/2" lower roll and lubricate the needle bearing as well.

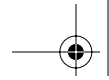

VE270FSD

AIR BLEEDING

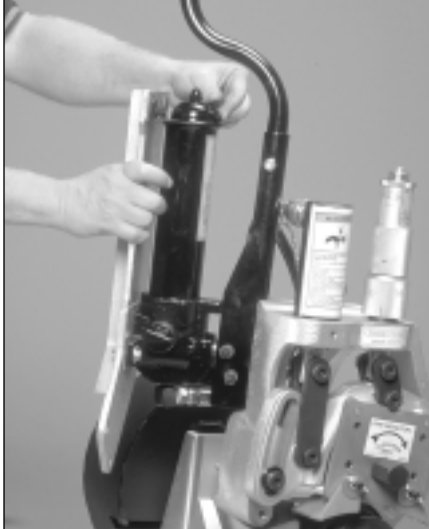

- 1.** To bleed air from the system, hold the entire pump above the hydraulic cylinder. Close the pump release valve by turning clockwise. Open fill plug one full turn.
- 2.** Pump the pump handle several strokes to build pressure.
- 3.** Open release valve by turning counterclockwise and allow air to escape.
- 4.** Repeat steps 1 - 3 several times to bleed all the air from the system.
- 5.** Check oil level and add oil if necessary.
- 6.** Continue to hold the pump above the hydraulic cylinder and close the fill plug.
- 7.** Install the pump and pump support assembly securely to the side of the tool.

PARTS ORDERING INFORMATION

When ordering parts, the following information is necessary for Victaulic to process the order and send the correct part(s). Request RP-270FSD Parts Manual for detailed drawings and parts listing.

- 1.** Tool Model Number, VE270FSD.
- 2.** Tool Serial Number. The serial number can be found stamped onto the tool body.
- 3.** Quantity, Part Number and Description. For example: Part # NK01060900, Woodruff Key.
- 4.** Where to send the part(s).
Company name
Address
- 5.** To whose attention to send the part(s).
Person's name
- 6.** Purchase Order Number

Order parts from the nearest Victaulic sales office. Consult the back page of this Instruction Manual for the nearest Victaulic Sales Office.

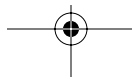

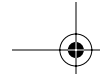

VE270FSD

ACCESSORIES

VICTAULIC ADJUSTABLE PIPE STANDS

VAPS 112



Victaulic Model 112, a portable, adjustable, roller type, four-leg pipe stand for use with Series VE270FSD and other Victaulic roll grooving tools, is available from Victaulic. Ball transfer rollers, adjustable for pipe from 3/4 - 12", will accommodate linear and rotational movement. Turnstile design permits easy swivel for grooving both pipe ends. Contact Victaulic for details.



STABILIZER ASSEMBLY



A pipe stabilizer is available for Series VE270FSD tools. It is designed to prevent pipe sway on 8 - 12" nominal IPS pipe sizes. Contact Victaulic for details.

OPTIONAL ROLLS

See Tool Rating and Roll Selection charts on pages 27 and 28 for rolls for different materials and groove specifications.

VAPS 224



Also available is Victaulic Model 224. It has features similar to Model 112. It is suitable for pipe sizes from 2 - 24". Consult Victaulic for details.

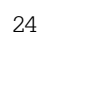

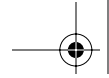

VE270FSD

TROUBLESHOOTING

Problem	Possible Cause	Solution
Pipe will not stay in grooving rolls.	Incorrect pipe positioning on long pipes.	See "Pipe Support".
Pipe stops rotating during grooving.	Rust or dirt has built up on lower roll. Rust or dirt is excessively heavy inside the pipe end. Worn grooving rolls. Woodruff key(s) under 2" and larger lower roll are broken or missing. Motor has stalled due to excess hand pumping. Circuit breaker has tripped or fuse has blown on electrical circuit supplying motor.	Remove accumulation from lower roll with stiff wire brush. Remove heavy rust and dirt from inside pipe end. See "Pipe Preparation". Inspect lower roll for worn knurls, replace if worn. Remove lower roll and insert punch tool in key removal hole(s). Press out the remains of broken key(s) and install new Woodruff #605 and/or #608 key(s). Install lower roll, see Roll Changing. Open release valve to free pipe, close release valve and continue grooving, pumping at a moderate rate. Reset breaker or replace fuse.
While grooving, loud squeaks echo through the pipe.	Incorrect pipe support positioning on long pipes, pipe is "over-tracking". Pipe not square cut. Pipe is rubbing excessively hard on lower roll flange.	Move pipe support to the right. See "Long Pipe Lengths". Cut pipe end squarely. Remove pipe from tool and apply a film of grease to the face of the lower roll flange as needed.
During grooving, loud thumps or bangs occur about once every revolution of the pipe.	Pipe has a pronounced weld seam.	Grind welds flush with pipe surface inside and out 2" back from pipe end.

Continued on next page.

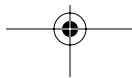

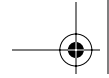

VE270FSD

TROUBLESHOOTING

Problem	Possible Cause	Solution
Pipe flare is excessive.	<p>Pipe support adjusted too high on long pipes.</p> <p>Tool is tilted forward while grooving long pipes.</p> <p>Incorrect pipe support positioning on long pipes, pipe is "over-tracking".</p> <p>Stabilizer is adjusted too far inward.</p>	<p>See "Long Pipe Lengths".</p> <p>See "Tool Setup".</p> <p>Move pipe support to right. See "Long Pipe Lengths".</p> <p>Back off stabilizer to the furthest point where it still stabilizes pipe effectively.</p>
Pipe sways or vibrates from side to side.	<p>Incorrect stabilizer adjustment.</p> <p>Optional stabilizer was not purchased, installed and used.</p>	<p>Move stabilizer in or out until pipe rotates smoothly.</p> <p>Purchase, install and use optional stabilizer.</p>
Tool won't groove pipe.	<p>Hand pump valve is not closed tightly.</p> <p>Hand pump is low on oil.</p> <p>Air in hydraulic system.</p> <p>Pipe beyond tool's wall thickness capability.</p>	<p>Tighten valve.</p> <p>See "Maintenance".</p> <p>See "Maintenance".</p> <p>See "Tool Rating and Roll Selection".</p>

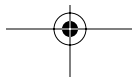

VE270FSD

TOOL RATING AND ROLL SELECTION

STANDARD AND "ES" ROLLS - COLOR CODED BLACK

2468-2B

PIPE SIZE Nom. Inches Actual mm	1		2		3		4		Standard Roll Nos.	"ES" Roll Nos.
	Nominal Dimensions - Inches/mm									
	Steel Pipe Wall Thickness		Stain. Steel Pipe Wall Thickness		Alum. Pipe Wall Thickness		PVC Plastic Pipe Wall Thickness			
	Min.	Max.	Min.	Max.	Min.	Max.	Min.	Max.		
¾ 26,9	0.065 1,7	0.113 2,9	0.065 1,7	0.113 2,9	0.065 1,7	0.113 2,9	0.113 2,9	0.113 2,9	Lower Roll R900268L013 Upper Roll R9A0268U024	NOT APPLICABLE
1 33,7	0.065 1,7	0.133 3,4	0.065 1,7	0.133 3,4	0.065 1,7	0.133 3,4	0.133 3,4	0.133 3,4	Lower Roll R901268L024 Upper Roll R9A0268U024	NOT APPLICABLE
1¼ 42,4	0.065 1,7	0.140 3,6	0.065 1,7	0.140 3,6	0.065 1,7	0.140 3,6	0.140 3,6	0.140 3,6	Lower Roll R901268L024 Upper Roll R9A0268U024	NOT APPLICABLE
1½ 48,3	0.065 1,7	0.145 3,7	0.065 1,7	0.145 3,7	0.065 1,7	0.145 3,7	0.145 3,7	0.145 3,7	Lower Roll R902272L03 Upper Roll R9A2272U06	Lower Roll RZ02272L03 Upper Roll RZA2272U03
2 60,3	0.065 1,7	0.154 3,9	0.154 3,9	0.154 3,9	0.065 1,7	0.154 3,9	0.154 3,9	0.154 3,9	Lower Roll R902272L03 Upper Roll R9A2272U06	Lower Roll RZ02272L03 Upper Roll RZA2272U03
2½ 73,0	0.083 2,1	0.203 5,2	0.203 5,2	0.203 5,2	0.083 2,1	0.203 5,2	0.203 5,2	0.276 7,0	Lower Roll R904272L06 Upper Roll R9A2272U06	Lower Roll RZ04272L06 Upper Roll RZA4272U06
3 88,9	0.083 2,1	0.216 5,5	0.216 5,5	0.216 5,5	0.083 2,1	0.216 5,5	0.216 5,5	0.300 7,6	Lower Roll R904272L06 Upper Roll R9A2272U06	Lower Roll RZ04272L06 Upper Roll RZA4272U06
3½ 101,6	0.083 2,1	0.226 5,7	0.226 5,7	0.226 5,7	0.083 2,1	0.226 5,7	0.226 5,7	0.318 8,1	Lower Roll R904272L06 Upper Roll R9A2272U06	Lower Roll RZ04272L06 Upper Roll RZA4272U06
4 114,3	0.083 2,1	0.237 6,0	0.237 6,0	0.237 6,0	0.083 2,1	0.237 6,0	0.237 6,0	0.337 8,6	Lower Roll R904272L06 Upper Roll R9A2272U06	Lower Roll RZ04272L06 Upper Roll RZA4272U06
4½ 127,0	0.095 2,4	0.237 6,0	0.237 6,0	0.237 6,0	0.095 2,4	0.237 6,0	- -	- -	Lower Roll R904272L06 Upper Roll R9A2272U06	Lower Roll RZ04272L06 Upper Roll RZA4272U06
5 141,3	0.109 2,8	0.258 6,6	0.258 6,6	0.258 6,6	0.109 2,8	0.258 6,6	0.258 6,6	0.375 9,5	Lower Roll R904272L06 Upper Roll R9A2272U06	Lower Roll RZ04272L06 Upper Roll RZA4272U06
6 O.D. 152,4	0.109 2,8	0.258 6,6	0.258 6,6	0.258 6,6	0.109 2,8	0.258 6,6	- -	- -	Lower Roll R904272L06 Upper Roll R9A2272U06	Lower Roll RZ04272L06 Upper Roll RZA4272U06
6 168,3	0.109 2,8	0.280 7,1	0.280 7,1	0.280 7,1	0.109 2,8	0.280 7,1	0.280 7,1	0.432 11,0	Lower Roll R908272L12 Upper Roll R9A8272U12	Lower Roll RZ08272L12 Upper Roll RZA8272U12
8 O.D. 203,2	0.109 2,8	0.322 8,2	0.250 6,4	0.322 8,2	0.109 2,8	0.322 8,2	0.322 8,2	0.322 8,2	Lower Roll R908272L12 Upper Roll R9A8272U12	Lower Roll RZ08272L12 Upper Roll RZA8272U12
8 219,1	0.109 2,8	0.322 8,2	0.250 6,4	0.322 8,2	0.109 2,8	0.322 8,2	0.322 8,2	0.322 8,2	Lower Roll R908272L12 Upper Roll R9A8272U12	Lower Roll RZ08272L12 Upper Roll RZA8272U12
10 273,0	0.134 3,4	0.250 6,4	0.250 6,4	0.250 6,4	0.134 3,4	0.250 6,4	0.365 9,3	0.365 9,3	Lower Roll R908272L12 Upper Roll R9A8272U12	Lower Roll RZ08272L12 Upper Roll RZA8272U12
12 323,9	0.156 4,0	0.250 6,4	0.250 6,4	0.250 6,4	0.156 4,0	0.250 6,4	0.406 10,3	0.406 10,3	Lower Roll R908272L12 Upper Roll R9A8272U12	Lower Roll RZ08272L12 Upper Roll RZA8272U12

STANDARD AND "ES" ROLLS NOTES:

COLUMN 1: Maximum ratings on steel are limited to pipe of 180 BHN (Brinell Hardness Number) and less.

COLUMN 2: Types 304/304L and 316/316L

COLUMN 3: Alloys 6061-T4 and 6063-T4

COLUMN 4: PVC Type I Grade I - PVC1120; PVC Type I Grade II - PVC1220; PVC Type II Grade I - PVC2116

All wall thicknesses are nominal minimum and maximum.

The following O.D. sized pipe also may be roll grooved: 3" O.D., 4¼" O.D., 5¼" O.D., 5½" O.D., 6¼" O.D., 6½" O.D., 8" O.D. and 12" O.D.
Contact Victaulic for details.

VE270FSD

**ROLLS FOR SCHEDULE 5S AND 10S STAINLESS STEEL PIPE
(RX ROLLS) – COLOR CODED SILVER**

0886-3A

PIPE SIZE Nominal Inches Actual mm	Nominal Dimensions – Inches/mm		RX Roll Nos.
	Stainless Steel Pipe Wall Thickness †		
	Min. Schedule 5S	Max. Schedule 10S	
2 60,3	0,065 1,7	0,109 2,8	Lower Roll RX02272L03
2½ 73,0	0,083 2,1	0,120 3,0	
3 88,9	0,083 2,1	0,120 3,0	Upper Roll RXA2272U06
3½ 101,6	0,083 2,1	0,120 3,0	Lower Roll RX04272L06
4 114,3	0,083 2,1	0,120 3,0	
5 141,3	0,109 2,8	0,134 3,4	
6 168,3	0,109 2,8	0,134 3,4	Upper Roll RXA2272U06
8 219,1	0,109 2,8	0,148 3,8	Lower Roll RX08272L12
10 273,0	0,134 3,4	0,165 4,2	
12 323,9	0,156 4,0	0,180 4,6	Upper Roll RXA8272U12

All wall thicknesses are nominal minimum and maximum.

† Types 304/304L and 316/316L.

The following O.D. sized pipe also may be roll grooved: 3" O.D., 4¼" O.D., 5¼" O.D., 5½" O.D., 6" O.D., 6¼" O.D., 6½" O.D., 8" O.D. and 12" O.D. Contact Victaulic for details.

ROLLS FOR COPPER TUBING – COLOR CODED COPPER †

0886-4A

PIPE SIZE Nominal Inches Actual mm	Nominal Dimensions – Inches/mm		Copper Roll Nos.
	Copper Tubing Wall Thickness		
	Min.	Max.	
2 60,3	0,042 1,1	0,083 2,1	Lower Roll RR02272L06
2½ 73,0	0,065 1,7	0,095 2,4	
3 88,9	0,045 1,1	0,109 2,8	Upper Roll RRA2272U06
3½ 101,6	0,058 1,5	0,134 3,4	
4 114,3	0,072 1,8	0,160 4,1	
5 141,3	0,083 2,1	0,192 4,9	Lower Roll RR08272L08
6 168,3	0,109 2,8	0,271 6,9	
			Upper Roll RRA8272U08

† Drawn copper tubing – DWV, ASTM B306 – Type "M", ASTM B88 – Type "L", ASTM B88 – Type "K", ASTM B88.

All wall thicknesses are nominal minimum and maximum.

VE270FSD

ROLL GROOVE SPECIFICATIONS

STEEL PIPE AND ALL MATERIALS GROOVED WITH STANDARD AND RX ROLLS

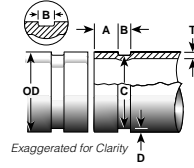

0886-5A

1 PIPE SIZE Nominal Inches Actual mm	2		3	4	5		6	7	8	
	Dimensions – Inches/millimeters									
	Pipe Outside Dia. O.D.		Gasket Seat A ±0.03 ±0.76	Groove Width B ±0.03 ±0.76	Groove Dia. – C		Groove Depth D (ref.)	Nom. Min. Allow. Wall Thk. T	Max. Allow. Flare Dia.	
Basic	Tolerance + -	Basic			Tol. +0.000 +0.00					
¾ 26,9	1.050 26,9	0.010 0,25	0.010 0,25	0.625 15,88	0.281 7,14	0.938 23,83	-0.015 -0,38	0.056 1,42	0.065 1,65	1.15 29,2
1 33,7	1.315 33,7	0.013 0,33	0.013 0,33	0.625 15,88	0.281 7,14	1.190 30,23	-0.015 -0,38	0.063 1,60	0.065 1,65	1.43 36,3
1¼ 42,4	1.660 42,4	0.016 0,41	0.016 0,41	0.625 15,88	0.281 7,14	1.535 38,99	-0.015 -0,38	0.063 1,60	0.065 1,65	1.77 45,0
1½ 48,3	1.900 48,3	0.019 0,48	0.019 0,48	0.625 15,88	0.281 7,14	1.775 45,09	-0.015 -0,38	0.063 1,60	0.065 1,65	2.01 51,1
2 60,3	2.375 60,3	0.024 0,61	0.024 0,61	0.625 15,88	0.344 8,74	2.250 57,15	-0.015 -0,38	0.063 1,60	0.065 1,65	2.48 63,0
2½ 73,0	2.875 73,0	0.029 0,74	0.029 0,74	0.625 15,88	0.344 8,74	2.720 69,09	-0.018 -0,46	0.078 1,98	0.083 2,11	2.98 75,7
3 O.D. 76,1	3.000 76,1	0.030 0,76	0.030 0,76	0.625 15,88	0.344 8,74	2.845 72,86	-0.018 -0,46	0.078 1,98	0.083 2,11	3.10 78,7
3 88,9	3.500 88,9	0.035 0,89	0.031 0,79	0.625 15,88	0.344 8,74	3.344 84,94	-0.018 -0,46	0.078 1,98	0.083 2,11	3.60 91,4
3½ 101,6	4.000 101,6	0.040 1,02	0.031 0,79	0.625 15,88	0.344 8,74	3.834 97,38	-0.020 -0,51	0.083 2,11	0.083 2,11	4.10 104,1
4¼ O.D. 108,0	4.250 108,0	0.043 1,04	0.031 0,79	0.625 15,88	0.344 8,74	4.084 103,73	-0.020 -0,51	0.083 2,11	0.083 2,11	4.35 110,5
4 114,3	4.500 114,3	0.045 1,14	0.031 0,79	0.625 15,88	0.344 8,74	4.334 110,08	-0.020 -0,51	0.083 2,11	0.083 2,11	4.60 116,8
4½ 127,0	5.000 127,0	0.050 1,27	0.031 0,79	0.625 15,88	0.344 8,74	4.834 122,78	-0.020 -0,51	0.083 2,11	0.095 2,41	5.10 129,5
5¼ O.D. 133,0	5.250 133,0	0.053 1,34	0.031 0,79	0.625 15,88	0.344 8,74	5.084 129,13	-0.020 -0,51	0.083 2,11	0.109 2,77	5.35 135,9
5½ O.D. 139,7	5.500 139,7	0.056 1,42	0.031 0,79	0.625 15,88	0.344 8,74	5.334 135,48	-0.020 -0,51	0.083 2,11	0.109 2,77	5.60 142,2
5 141,3	5.563 141,3	0.056 1,42	0.031 0,79	0.625 15,88	0.344 8,74	5.395 137,03	-0.022 -0,56	0.084 2,13	0.109 2,77	5.66 143,8
6 O.D. 152,4	6.000 152,4	0.056 1,42	0.031 0,79	0.625 15,88	0.344 8,74	5.830 148,08	-0.022 -0,56	0.085 2,16	0.109 2,77	6.10 154,9
6¼ O.D. 159,0	6.250 159,0	0.063 1,60	0.031 0,79	0.625 15,88	0.344 8,74	6.032 153,21	-0.030 -0,56	0.085 2,16	0.109 2,77	6.35 161,3
6½ O.D. 165,1	6.500 165,1	0.063 1,60	0.031 0,79	0.625 15,88	0.344 8,74	6.330 160,78	-0.022 -0,56	0.085 2,16	0.109 2,77	6.60 167,6
6 168,3	6.625 168,3	0.063 1,60	0.031 0,79	0.625 15,88	0.344 8,74	6.455 163,96	-0.022 -0,56	0.085 2,16	0.109 2,77	6.73 170,9
8 O.D. 203,2	8.000 203,2	0.063 1,60	0.031 0,79	0.750 19,05	0.469 11,91	7.816 198,53	-0.025 -0,64	0.092 2,34	0.109 2,77	8.17 207,5

Table continued on next page.

VE270FSD

0886-5A

1 PIPE SIZE Nominal Inches Actual mm	2			3	4	5		6	7	8
	Dimensions – Inches/millimeters									
	Pipe Outside Dia. O.D.			Gasket Seat A ±0.03 ±0.76	Groove Width B ±0.03 ±0.76	Groove Dia. – C		Groove Depth D (ref.)	Nom. Min. Allow. Wall Thk. T	Max. Allow. Flare Dia.
	Basic	Tolerance + -				Basic	Tol. +0.000 +0.00			
8 219,1	8.625 219,1	0.063 1,60	0.031 0,79	0.750 19,05	0.469 11,91	8.441 214,40	-0.025 -0,64	0.092 2,34	0.109 2,77	8.80 223,5
10 O.D. 254,0	10.000 254,0	0.063 1,60	0.031 0,79	0.750 19,05	0.469 11,91	9.812 249,23	-0.027 -0,69	0.094 2,39	0.134 3,40	10.17 258,3
10 273,0	10.750 273,0	0.063 1,60	0.031 0,79	0.750 19,05	0.469 11,91	10.562 268,28	-0.027 -0,69	0.094 2,39	0.134 3,40	10.92 277,4
12 O.D. 304,8	12.000 304,8	0.063 1,60	0.031 0,79	0.750 19,05	0.469 11,91	11.781 299,24	-0.030 -0,76	0.109 2,77	0.156 3,96	12.17 309,1
12 323,9	12.750 323,9	0.063 1,60	0.031 0,79	0.750 19,05	0.469 11,91	12.531 318,29	-0.030 -0,76	0.109 2,77	0.156 3,96	12.92 328,2

STANDARD ROLL GROOVE SPECIFICATIONS NOTES (FROM PAGE 29):

COLUMN 1: **Nominal IPS pipe size.**

COLUMN 2: **IPS outside diameter:** The outside diameter of roll grooved pipe shall not vary more than the tolerance listed. For IPS pipe the maximum allowable tolerance from square cut ends is 0.030" for ¾ - 3½"; 0.045" for 4 - 6"; and 0.060" for sizes 8" O.D. and above measured from true square line.

COLUMN 3: **Gasket seat:** The pipe surface shall be free from indentations, roll marks, and projections from the end of the pipe to the groove, to provide a leak-tight seal for the gasket. All loose paint, scale, dirt, chips, grease and rust must be removed. It continues to be Victaulic's first recommendation that pipe be square cut. When using beveled pipe contact Victaulic for details. Square cut pipe **must** be used with FlushSeal® and EndSeal® gaskets. Gasket seat "A" is measured from the end of the pipe. **IMPORTANT:** Roll grooving of beveled end pipe may result in unacceptable pipe end flare. See column 8.

COLUMN 4: **Groove width:** Bottom of groove to be free of loose dirt, chips, rust and scale that may interfere with proper coupling assembly. Corners at bottom of groove must be radiused. For IPS steel pipe, .06R on ¾ - 1½", .08R on 2 - 6", .05R on 8" and up.

COLUMN 5: **Groove outside diameter:** The groove must be of uniform depth for the entire pipe circumference. Groove must be maintained within the "C" diameter tolerance listed.

COLUMN 6: **Groove depth:** For reference only. Groove must conform to the groove diameter "C" listed.

COLUMN 7: **Minimum allowable wall thickness:** This is the minimum wall thickness which may be roll grooved – except PVC.

COLUMN 8: **Maximum allowable pipe end flare diameter:** Measured at the most extreme pipe end diameter square cut or beveled.

VE270FSD

DRAWN COPPER TUBING

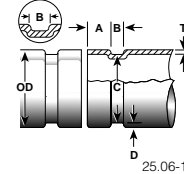

25.06-1A

1 TUBING SIZE Nom. Inches Actual mm	2 Pipe O.D. Inches/mm		3 Dimensions – Inches/millimeters					8 Max. Allow. Flare Dia.
	Basic	Tol.	4 Gask. Seat A ±0.03/±0.76	5 Grv. Width B +0.03/-0.00 +0.76/-0.00	6 Groove Dia. C +0.00	7 Grv. Depth (ref.) D	Min. Allow. Wall Thick. T	
2 54,0	2.125 54,0	±0.002 ±0,05	0.610 15,5	0.300 7,6	2.029 51,5	0.048 1,2	0.064 1,6	2.220 56,4
2½ 66,7	2.625 66,7	±0.002 ±0,05	0.610 15,5	0.300 7,6	2.525 64,1	0.050 1,2	0.065 1,7	2.720 69,1
3 79,4	3.125 79,4	±0.002 ±0,05	0.610 15,5	0.300 7,6	3.025 76,8	0.050 1,2	DWV	3.220 81,8
4 104,8	4.125 104,8	±0.002 ±0,05	0.610 15,5	0.300 7,6	4.019 102,1	0.053 1,4	DWV	4.220 107,2
5 130,2	5.125 130,2	±0.002 ±0,05	0.610 15,5	0.300 7,6	4.999 127,0	0.053 1,4	DWV	5.220 132,6
6 155,6	6.125 155,6	±0.002 ±0,05	0.610 15,5	0.300 7,6	5.999 152,3	0.063 1,6	DWV	6.220 158,0
8 206,4	8.125 206,4	* *	0.610 15,5	0.300 7,6	7.959 202,2	0.083 2,1	DWV	8.220 208,8

* Tolerances for 8" (206,4 mm) are: +0.002 (0,05 mm), -0.004 (-0,10 mm).

COPPER TUBING ROLL SPECIFICATIONS NOTES:

COLUMN 1: **Nominal ASTM B-88 drawn copper tubing size.**

COLUMN 2: **Outside diameter:** The outside diameter of roll grooved tubing shall not vary more than the tolerance listed. The maximum allowable tolerance from square cut ends is 0.030" (0,8 mm) for 2 - 3" (54,0 - 79,4 mm); 0.045" (1,1 mm) for 4 - 6" (104,8 - 155,6 mm), measured from true square line.

COLUMN 3: **Gasket seat:** The tubing surface shall be free from indentations, roll marks, and projections from the end of the tubing to the groove, to provide a leak-tight seat for the gasket. All loose scale, dirt, chips and grease must be removed.

COLUMN 4: **Groove width:** Bottom of groove to be free of loose dirt, chips and scale that may interfere with proper coupling assembly.

COLUMN 5: **Groove outside diameter:** The groove must be uniform depth for the entire tubing circumference. Groove must be maintained within the "C" diameter tolerance listed.

COLUMN 6: **Groove depth:** For reference only. Groove must conform to the groove diameter "C" listed.

COLUMN 7: **Minimum allowable wall thickness:** ASTM B-306 drain waste and vent (DWV) is minimum wall thickness copper tubing which may be roll grooved.

COLUMN 8: **Maximum allowable end flare diameter:** Measured at the most extreme tubing end dia.

VE270FSD

**STEEL PIPE AND ALL MATERIALS
GROOVED WITH "ES" ROLLS**

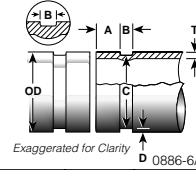

1 PIPE SIZE Nom. In. Actual mm	2 Dimensions – Inches/mm											
	Pipe Outside Dia. O.D.			Gasket Seat A		Groove Width B		Groove Dia. C		Grv. Depth (ref.) D	Nom. Min. Allow. Wall Thick. T	Max. Allow. Flare Dia.
	Basic	Tolerance +	-	Basic	Tol. +0.000 +0.00	Basic	Tol. -0.000 -0.00	Basic	Tol. +0.000 +0.00			
2 60.3	2.375 60.3	+0.024 +0.61	-0.024 -0.61	0.572 14.53	-0.020 -0.51	0.250 6.35	+0.015 +0.38	2.250 57.15	-0.015 -0.38	0.063 1.60	0.065 1.65	2.48 63.0
2½ 73.0	2.875 73.0	+0.029 +0.74	-0.029 -0.74	0.572 14.53	-0.020 -0.51	0.250 6.35	+0.015 +0.38	2.720 69.09	-0.018 -0.46	0.078 1.98	0.083 2.11	2.98 75.7
3 88.9	3.500 88.9	+0.035 +0.89	-0.031 -0.79	0.572 14.53	-0.020 -0.51	0.250 6.35	+0.015 +0.38	3.344 84.94	-0.018 -0.46	0.078 1.98	0.083 2.11	3.60 91.4
4 114.3	4.500 114.3	+0.045 +1.14	-0.031 -0.79	0.610 15.49	-0.020 -0.51	0.300 7.62	+0.020 +0.51	4.334 110.08	-0.020 -0.51	0.083 2.11	0.083 2.11	4.60 116.8
6 168.3	6.625 168.3	+0.063 +1.60	-0.031 -0.79	0.610 15.49	-0.020 -0.51	0.300 7.62	+0.020 +0.51	6.455 163.96	-0.022 -0.56	0.085 2.16	0.109 2.77	6.73 170.9
8 219.1	8.625 219.1	+0.063 +1.60	-0.031 -0.79	0.719 18.26	-0.020 -0.51	0.390 9.91	+0.020 +0.51	8.441 214.40	-0.025 -0.64	0.092 2.34	0.109 2.77	8.80 223.5
10 273.0	10.750 273.0	+0.063 +1.60	-0.031 -0.79	0.719 18.26	-0.020 -0.51	0.390 9.91	+0.020 +0.51	10.562 268.28	-0.027 -0.69	0.094 2.39	0.134 3.40	10.92 277.4
12 323.9	12.750 323.9	+0.063 +1.60	-0.031 -0.79	0.719 18.26	-0.020 -0.51	0.390 9.91	+0.020 +0.51	12.531 318.29	-0.030 -0.76	0.109 2.77	0.156 3.96	12.92 328.2

"ES" ROLL GROOVE SPECIFICATIONS NOTES

COLUMN 1: Nominal IPS pipe size.

COLUMN 2: **IPS outside diameter. Metric (ISO) outside diameter:** The outside diameter of roll grooved pipe shall not vary more than the tolerance listed. For IPS pipe, the maximum allowable tolerance from square cut ends is 0.030" for ¾ - 3½" (26,9 - 101,6 mm); 0.045" for 4 - 6" (114,3 - 168,3 mm); and 0.060" for sizes 8" O.D. (203,2 mm) and above measured from true square line. For (ISO) metric pipe, the maximum allowable tolerance from square cut ends is 0.76 mm for sizes 26,9 mm - 88,9 mm; 1.14 mm for sizes 114,3 mm - 168,3 mm; and 1.52 mm for sizes 219,1 mm and above, measured from the true square line.

COLUMN 3: **Gasket seat:** The pipe surface shall be free from indentations, roll marks, and projections from the end of the pipe to the groove, to provide a leak-tight seal for the gasket. All loose paint, scale, dirt, chips, grease and rust must be removed. Square cut pipe must be used with FlushSeal® and EndSeal® gaskets. Gasket seat "A" is measured from the end of the pipe. IMPORTANT: Roll grooving of beveled end pipe may result in unacceptable pipe end flare. See column 8.

COLUMN 4: **Groove width:** Bottom of groove to be free of loose dirt, chips, rust and scale that may interfere with proper coupling assembly. Corners at bottom of roll groove must be radiused. For IPS pipe, 0.04R on 1½ - 12" (48,3 - 323,9 mm). For (ISO) metric pipe, 1.2R mm on 26,9 - 323,9 mm.

COLUMN 5: **Groove outside diameter:** The groove must be uniform depth for the entire pipe circumference. Groove must be maintained within the "C" diameter tolerance listed.

COLUMN 6: **Groove depth:** For reference only. Groove must conform to the groove diameter "C" listed.

COLUMN 7: **Minimum allowable wall thickness:** This is the minimum wall thickness which may be grooved.

COLUMN 8: **Maximum allowable pipe end flare diameter:** Measured at the most extreme pipe end diameter square cut or beveled.

VE270FSD

DIMENSIONS

SEAMLESS AND WELDED STEEL PIPE*

2468-3A

PIPE SIZE Nominal Inches Actual mm	Pipe O.D. Inches mm	Nominal Wall Thickness – Inches/mm						
		Sch. 5S	Sch. 10S	Sch. 20	Sch. 30	Sch. 40	Sch. STD.	Sch. 80
¾ 26,9	1.050 26,9	0.065 1,7	0.083 2,1	— —	— —	0.113 2,9	0.113 2,9	0.154 3,9
1 33,7	1.315 33,7	0.065 1,7	0.109 2,8	— —	— —	0.133 3,4	0.133 3,4	0.179 4,5
1¼ 42,4	1.660 42,4	0.065 1,7	0.109 2,8	— —	— —	0.140 3,6	0.140 3,6	0.191 4,9
1½ 48,3	1.900 48,3	0.065 1,7	0.109 2,8	— —	— —	0.145 3,7	0.145 3,7	0.200 5,1
2 60,3	2.375 60,3	0.065 1,7	0.109 2,8	— —	— —	0.154 3,9	0.154 3,9	0.218 5,5
2½ 73,0	2.875 73,0	0.083 2,1	0.120 3,0	— —	— —	0.203 5,2	0.203 5,2	0.276 7,0
3 88,9	3.500 88,9	0.083 2,1	0.120 3,0	— —	— —	0.216 5,5	0.216 5,5	0.300 7,6
3½ 101,6	4.000 101,6	0.083 2,1	0.120 3,0	— —	— —	0.226 5,7	0.226 5,7	0.318 8,1
4 114,3	4.500 114,3	0.083 2,1	0.120 3,0	— —	— —	0.237 6,0	0.237 6,0	0.337 8,6
5 141,3	5.563 141,3	0.109 2,8	0.134 3,4	— —	— —	0.258 6,6	0.258 6,6	0.375 9,5
6 168,3	6.625 168,3	0.109 2,8	0.134 3,4	— —	— —	0.280 7,1	0.280 7,1	0.432 11,0
8 219,1	8.625 219,1	0.109 2,8	0.148 3,8	0.250 6,4	0.277 7,0	0.322 8,2	0.322 8,2	0.500 12,7
10 273,0	10.750 273,0	0.134 3,4	0.165 4,2	0.250 6,4	0.307 7,8	0.365 9,3	0.365 9,3	0.594 15,1
12 323,9	12.750 323,9	0.156 4,0	0.180 4,6	0.250 6,4	0.330 8,4	0.406 10,3	0.375 9,5	0.688 17,4

*For reference only. The VE270FSD can not groove all schedules of steel pipe in table.

DRAWN COPPER TUBING

0886-8B

TUBING SIZE Nominal Inches Actual mm	Outside Diameter	Nominal Wall Thickness – Inches/mm			
		DWV ASTM B-306	Type "M" ASTM B-88	Type "L" ASTM B-88	Type "K" ASTM B-88
2 54,0	2.125 54,0	0.042 1,1	0.058 1,5	0.070 1,8	0.083 2,1
2½ 66,7	2.625 66,7	—	0.065 1,7	0.080 2	0.095 2,4
3 79,4	3.125 79,4	0.045 1,1	0.072 1,8	0.090 2,3	0.109 2,8
4 104,8	4.125 104,8	0.058 1,5	0.095 2,4	0.110 2,8	0.134 3,4
5 130,2	5.125 130,2	0.072 1,8	0.109 2,8	0.125 3,2	0.160 4,1
6 155,6	6.125 155,6	0.083 2,1	0.122 3,1	0.140 3,6	0.192 4,9
8 206,4	8.125 206,4	0.109 2,8	0.170 4,3	0.200 5,1	0.271 6,9



Victaulic Tool Company

Tool Shipments:
1326 Tatamy Road, Easton, PA 18045-7400
Sales & Lease Payments:
P.O. Box 8588-244, Phila., PA 19171-0244

CUSTOMER CARE CENTER

Phone: 1-800-PICK-VIC (1-800-742-5842)
e-mail: pickvic@victaulic.com
FAX: 610/923-3090

WORLD HEADQUARTERS

P.O. Box 31 • Easton, PA 18044-0031
4901 Kesslersville Road • Easton, PA, USA 18040
Phone: 610/559-3300 • FAX: 610/250-8817

VICTAULIC COMPANY OF AMERICA

P.O. Box 31 • Easton, PA 18044-0031
Phone: 610/559-3300 • Fax: 610/250-8817

**Fire Protection Division
Customer Care Centers**

■ **SOUTHEAST FIRE PROTECTION**

Phone: 877/773-8322 • Fax: 877/776-9769

■ **NORTHEAST FIRE PROTECTION**

Phone: 888/265-0805 • Fax: 888/265-0918

■ **CENTRAL FIRE PROTECTION**

Phone: 888/448-3534 • Fax: 888/448-3595

■ **WESTERN FIRE PROTECTION**

Phone: 877/487-7231 • Fax: 877/487-7232

Victaulic Tool Company

P.O. Box 31 • Easton, PA 18044-0031
Phone: 610/559-3300 • Fax: 610/923-3090

Victaulic Municipal Division

1818 Vultee Street • Allentown, PA 18103
Phone: 610/559-3488 • Fax: 610/923-3170

Victaulic Construction Piping Services

1818 Vultee Street • Allentown, PA 18103
Phone: 610/559-3488 • Fax: 610/923-3170

United States Distribution Centers

■ **NEW YORK METRO**

4901 Kesslersville Road • Easton, PA 18040
Cust.Care: 800/742-5842 • Cust. Fax: 800/437-6573

■ **SOUTHEAST**

650 Coastline Drive • Yulee, FL 32097
Cust.Care: 800/742-5842 • Cust. Fax: 888/201-3468

■ **MIDWEST**

730 Thomas Drive • Bensenville, IL 60106
Cust.Care: 800/742-5842 • Cust. Fax: 888/265-2018

■ **GREAT LAKES**

23107 Commerce Drive • Farmington Hills, MI 48335
Cust.Care: 800/742-5842 • Cust. Fax: 800/564-0119

■ **CENTRAL STATES**

5900 Deramus Avenue • Kansas City, MO 64120
Cust.Care: 800/742-5842 • Cust. Fax: 888/448-3540

■ **MID-CONTINENT**

7177 Railspur Street • Houston, TX 77078
Cust.Care: 800/742-5842 • Cust. Fax: 888/448-3537

■ **PERMIAN BASIN**

2628 Remington Road • Odessa, TX 79763
Local Tel.: 915/332-1489 • Local Fax: 915/332-4924

■ **ROCKY MOUNTAIN**

5045 Paris Street • Denver, CO 80239
Cust.Care: 800/742-5842 • Cust. Fax: 888/448-3528

■ **PACIFIC - NORTH**

22633 83rd Ave. So. • Kent, WA 98032
Cust.Care: 800/742-5842 • Cust. Fax: 888/448-3530

■ **MID-ATLANTIC**

4901 Kesslersville Road • Easton, PA 18040
Cust.Care: 800/742-5842 • Cust. Fax: 800/696-6447

■ **PACIFIC - SOUTH**

20934 So. Santa Fe Ave. • Long Beach, CA 90810
Cust.Care: 800/742-5842 • Cust. Fax: 800/448-3542

VICTAULIC COMPANY OF CANADA

65 Worcester Road • Rexdale, Ontario • Canada M9W 5N7
Phone: 416/675-5575 • FAX: 416/675-5565 • e-mail: viccanda@victaulic.com

Canadian Sales Offices and Service Centers

■ **EASTERN**

975 rue Selkirk • Pointe Claire, PQ H9R 4S4
Phone: 514/426-3500 • FAX: 514/426-2818

■ **ONTARIO - NORTH**

1070 Elisabella Street • Sudbury, ON P3A 5K2
Phone: 705/560-9595 • FAX: 705/560-9490

■ **PACIFIC**

Unit 5, 7560 Vantage Way • Delta, BC V4G 1H1
Phone: 604/940-3301 • FAX: 604/940-3360

■ **ONTARIO - SOUTH**

65 Worcester Road • Rexdale, ON M9W 5N7
Phone: 416/675-5575 • FAX: 416/675-5729

■ **WESTERN**

15353 114th Avenue • Edmonton, AB T5M 3S9
Phone: 780/452-0680 • FAX: 780/452-2430

Victaulic® Factory Representatives and Distributor Stocks Worldwide

Victaulic reserves the right to change product specifications,
designs and standard equipment without notice and without obligation.