



# Operating and Maintenance Instructions Manual

## Series VE46

### Pipe Roll Grooving Tool

VE46S and VE46P Manual Feed, In-Place Roll Grooving Tools  
Adaptable for Motorized, Semi-Automatic Option

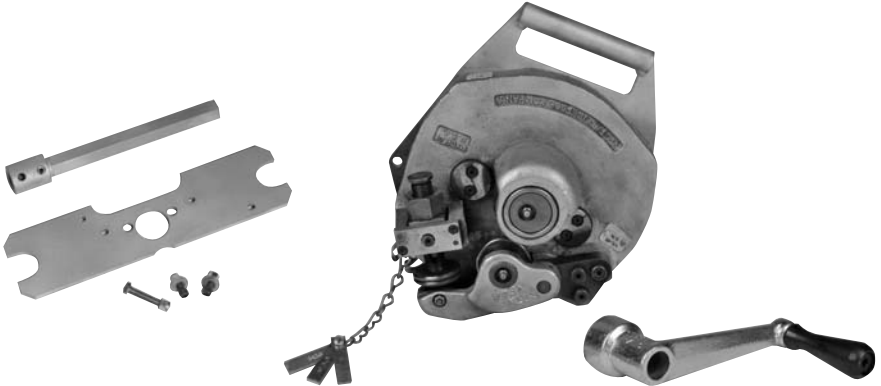

Patented and Patent Pending

#### **WARNING**



Failure to follow instructions and warnings could result in serious personal injury, property damage, and/or product damage.

- Before operating or servicing the VE46 Roll Grooving Tool, read all instructions in this manual and all warning labels on the tool.
- Wear safety glasses, hardhat, foot protection, and hearing protection.
- Save this operating and maintenance manual.

If you need additional copies of any literature, or if you have questions concerning the safe and proper operation of this tool, contact Victaulic Tool Company, P.O. Box 31, Easton, PA 18044-0031, Phone: 1-800-PICK VIC, e-mail: [pickvic@victaulic.com](mailto:pickvic@victaulic.com).



# INDEX

---

<b>Hazard Identification</b> .....	2	Dismounting the Tool .....	21
<b>Operator Safety Instructions</b> .....	3	<b>Grooving Operation</b>	
<b>Introduction</b> .....	5	<b>For Power Drive Setup</b> .....	22
Receiving the Tool .....	5	<b>Maintenance</b> .....	25
VE46 Container Contents .....	5	Lubrication .....	25
Optional Power Drive Kit Contents .....	5	<b>Parts Ordering Information</b> .....	26
<b>Power Requirements for VE46 Tools</b>		<b>Accessories</b> .....	26
<b>Used with a Power Drive</b> .....	6	VAPS 112 Victaulic Adjustable	
Power Drive .....	6	Pipe Stand .....	26
Extension Cord Requirements .....	6	VAPS 224 Victaulic Adjustable	
<b>Tool Nomenclature</b> .....	7	Pipe Stand .....	26
<b>Tool Setup</b> .....	8	VPD752 Power Drive .....	26
Pipe Vise Setup .....	8	<b>Troubleshooting</b> .....	27
Groove-In-Place Setup .....	8	General and "In-Place" Grooving .....	27
<b>Power Drive Mounting Plate</b>		Tools Installed on a Power Drive .....	28
<b>Kit Installation</b> .....	9	<b>Tool Ratings</b> .....	29
<b>Power Drive Setup</b> .....	10	VE46S for Steel and Schedule 40	
<b>Preparation for Grooving</b> .....	13	Stainless Steel Pipe .....	29
Pipe Preparation .....	13	VE46P for Aluminum and PVC Pipe .....	29
<b>Pipe Lengths Suitable for Grooving</b>		<b>Explanation of Critical Roll</b>	
<b>(Applies only to tools installed</b>		<b>Groove Dimensions</b> .....	30
<b>on a power drive)</b> .....	14	<b>Roll Groove Specifications</b> .....	31
Short Pipe Lengths .....	14	VE46S for Steel and Schedule 40	
Long Pipe Lengths .....	15	Stainless Steel Pipe .....	31
<b>Groove Depth Adjustment</b> .....	16	VE46P for Aluminum and PVC Pipe .....	31
<b>Grooving Operation For Pipe Vise</b>		<b>Facilities Locations</b> .....	B/C
<b>Setup or Groove-In-Place Setup</b> .....	18		

## HAZARD IDENTIFICATION

---

Definitions for identifying the various hazard levels are provided below.



This safety alert symbol indicates important safety messages. When you see this symbol, be alert to the possibility of personal injury. Carefully read and fully understand the message that follows.

### **DANGER**

- The use of the word “DANGER” identifies an immediate hazard with a likelihood of death or serious personal injury if instructions, including recommended precautions, are not followed.

### **WARNING**

- The use of the word “WARNING” identifies the presence of hazards or unsafe practices that could result in death or serious personal injury if instructions, including recommended precautions, are not followed.

### **CAUTION**

- The use of the word “CAUTION” identifies possible hazards or unsafe practices that could result in personal injury and product or property damage if instructions, including recommended precautions, are not followed.

### **NOTICE**

- The use of the word “NOTICE” identifies special instructions that are important but not related to hazards.

# OPERATOR SAFETY INSTRUCTIONS

The VE46 is designed only for roll grooving pipe. Use of this tool requires dexterity and mechanical skills, as well as sound safety habits. Although this tool is manufactured for safe, dependable operation, it is impossible to anticipate all the combinations of circumstances that could result in an accident. The following instructions are recommended for safe operation of this tool. The operator is cautioned to always practice "safety first" during each phase of use, including setup and maintenance. It is the responsibility of the owner, lessee, or user of this tool to ensure that all operators read this manual and fully understand the operation of this tool.

Read this manual before operating or servicing the tool. Become familiar with the tool's operations, applications, and limitations. Be particularly aware of its specific hazards. Store this manual in a clean area where it is always readily available. Additional copies of this manual are available upon request through the Victaulic Tool Company.

## GENERAL

- 1. This tool is designed ONLY for roll grooving pipe sizes, materials, and wall thicknesses listed in the "Tool Ratings" section, starting on page 29.**
- 2. Inspect the equipment.** Before using the tool, check all moveable parts for any obstructions. Make sure tool components are installed and adjusted properly.
- 3. Wear proper apparel.** Do not wear loose clothing, jewelry, or anything that can become entangled in moving parts.
- 4. Wear protective items when working with tools.** Always wear safety glasses, hardhat, and foot protection. Wear hearing protection when using power-driven tools.
- 5. Stay alert.** Do not operate the tool if you are drowsy from medication or fatigue. Avoid horseplay around the equipment.

**6. Keep visitors away from the immediate work area.** All visitors should be kept a safe distance from the equipment at all times. When using the tool at elevated locations as an "In-Place" groover, the area below must remain clear of other personnel to prevent injuries in case a tool or hand crank is accidentally dropped.

**7. Keep work areas clean.** Keep the work area around the tool clear of any obstructions that could limit the movement of the operator. Clean up any oil or other spills.

**8. Secure the pipe before performing the grooving operation.** Make sure the pipe is secured or otherwise capable of handling the weight of the tool and resisting the torque created when used as an "In-Place" groover.

**9. Keep hands and tools away from grooving rolls during the grooving operation.** Grooving rolls can crush or cut fingers and hands.

**10. Do not reach inside the pipe end during tool operation.**

**11. Do not force the tool.** Do not force the tool or accessories to perform any functions beyond their capabilities. Do not overload the tool.

**12. Do not operate the tool at speeds exceeding those specified in this manual.**

**13. Maintain tools with care.** Keep tools clean at all times to ensure proper and safe performance. Follow the instructions for lubricating tool components.

**14. When tools are not in use, store them in a dry, secure place.**

**15. Use only Victaulic replacement parts and accessories.** Use of any other parts may result in a voided warranty, improper operation, and hazardous situations. Refer to the "Parts Ordering Information" and "Accessories" section on page 26.

**16. Do not remove any labels from the tool.** Replace any damaged or worn labels.

## **TOOLS USED WITH A POWER DRIVE**

**1. VE46 tools that are intended for use with a power drive MUST have the optional power drive kit installed before attempting to groove pipe.**

**2. Avoid using the tool in dangerous environments.** Do not expose the tool to rain, and do not use the tool in damp or wet locations. Do not use the tool on sloped or uneven surfaces. Keep the work area well lit. Allow sufficient space to operate the tool properly.

**3. Ground the power drive to protect the operator from electric shock.** Make sure the power drive is connected to an internally grounded electrical source.

**4. Prevent accidental startups.** Place the switch on the power drive to the "OFF" position before plugging the unit into the electrical source.

**5. Operate the tool only with a safety foot switch.** The power drive must be operated with a safety foot switch that is located for easy operator access. Never reach across moving parts. If the power drive does not contain a safety foot switch, contact the power drive manufacturer.

**6. Secure the power drive.** Make sure the power drive is stable.

**7. Support the work.** Support long pipe lengths with a pipe stand that is secured to the floor or the ground.

**8. Do not over-reach.** Maintain proper footing and balance at all times. Make sure the safety foot switch is easily accessible for the operator.

**9. Do not abuse the safety foot switch cord.** Never yank the cord out of the receptacle. Keep the cord away from heat, oil, and sharp objects.

**10. Unplug the power drive from the electrical source before servicing the tool.** Only authorized personnel should attempt to perform maintenance on the tool. Always disconnect the power drive from the electrical source before servicing or adjusting the tool.

## INTRODUCTION

### NOTICE

- Drawings and/or pictures in this manual may be exaggerated for clarity.
- The tool, along with this operating and maintenance instructions manual, contains trademarks, copyrights, and/or patented features that are the exclusive property of Victaulic Company.

The Victaulic VE46 Roll Grooving Tool series is designed for roll grooving pipe to receive Victaulic grooved pipe products and can be used for either manual or power operation.

### CAUTION

- This tool must be used **ONLY** for roll grooving pipe designated in the “Tool Rating” section of this manual.

Failure to follow this instruction could overload the tool, resulting in reduced tool life and/or damage to the tool.

## RECEIVING THE TOOL

VE46 tools are packed individually in sturdy containers, which are designed for use in re-shipping tools back to Victaulic upon completion of the rental contract, when applicable.

Upon receipt of the tool, make sure all necessary parts are included. If any parts are missing, notify the Victaulic Tool Company.

## VE46 CONTAINER CONTENTS

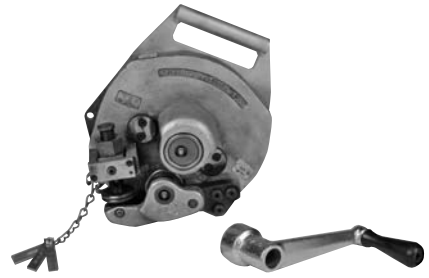

Qty.	Description
1	VE46 Tool (VE46S or VE46P Version, as Ordered)
1	Set of Groove Depth Gauges (Attached to Tool)
1	Hand Crank
2	VE46 Operating and Maintenance Instructions Manual
1	RP-VE46 Repair Parts List

## OPTIONAL POWER DRIVE KIT CONTENTS\*

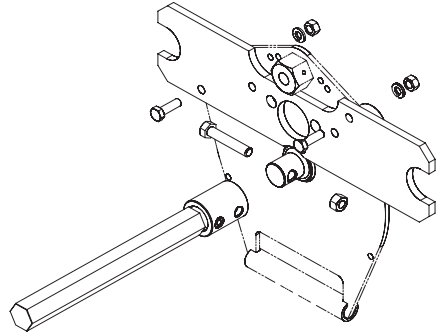

Qty.	Description
1	Power Drive Mounting Plate
1	Drive Shaft/Adapter
1	Hex-Head Bolt
1	Hex Nut with Nylon Insert
2	Hex-Head Cap Screw
2	Lock Washer
2	Hex Nut

\* Kit Part Number (R-075-026-KIT)

# POWER REQUIREMENTS FOR VE46 TOOLS USED WITH A POWER DRIVE

**! DANGER**



- To reduce the risk of electric shock, check the electrical source for proper grounding.
- Before performing any maintenance on the tool, turn the switch on the power drive to the "OFF" position, or disconnect the power cord from the electrical source.

Failure to follow these instructions could result in death or serious personal injury.

## POWER DRIVE

VE46 tools are designed for manual operation or operation with a power drive. For power operation, tools mount directly onto a Victaulic VPD752 Power Drive or a Ridgid® 300 Power Drive with a 38-rpm maximum chuck speed.

Power must be supplied to the power drive through a safety foot switch to ensure safe operation. Make sure the power drive is properly grounded in accordance with Article 250 of the National Electrical Code.

If an extension cord is required, refer to the "Extension Cord Requirements" section on this page for cord sizes. In addition, refer to the power drive manufacturer's instructions prior to use.

## EXTENSION CORD REQUIREMENTS

When pre-wired outlets are not available and an extension cord must be used, it is important to use the proper cord size (i.e. Conductor Size American Wire Gauge). Cord size selection is based upon tool rating (amps) and cord length (feet). Use of a cord size (gauge) thinner than required will cause significant voltage drop at the power drive while the tool is operating. Voltage drops may cause damage to the power drive and can result in improper tool operation. **NOTE:** It is acceptable to use a cord size (gauge) that is heavier than required.

The required cord sizes (gauges) for cord lengths up to and including 100 feet (31 m) are listed in the table below. Use of extension cords longer than 100 feet (31 m) must be avoided.

Power Drive Rating Volts (Amps)	Cord Lengths		
	25 feet (8 m)	50 feet (15 m)	100 feet (31 m)
115 (15)	12 gauge	12 gauge	10 gauge

®Ridgid is a registered trademark of The Ridge Tool Company.



# TOOL NOMENCLATURE

## NOTICE

- Drawings and/or pictures in this manual may be exaggerated for clarity.
- The tool, along with this operating and maintenance instructions manual, contains trademarks, copyrights, and/or patented features that are the exclusive property of Victaulic Company.

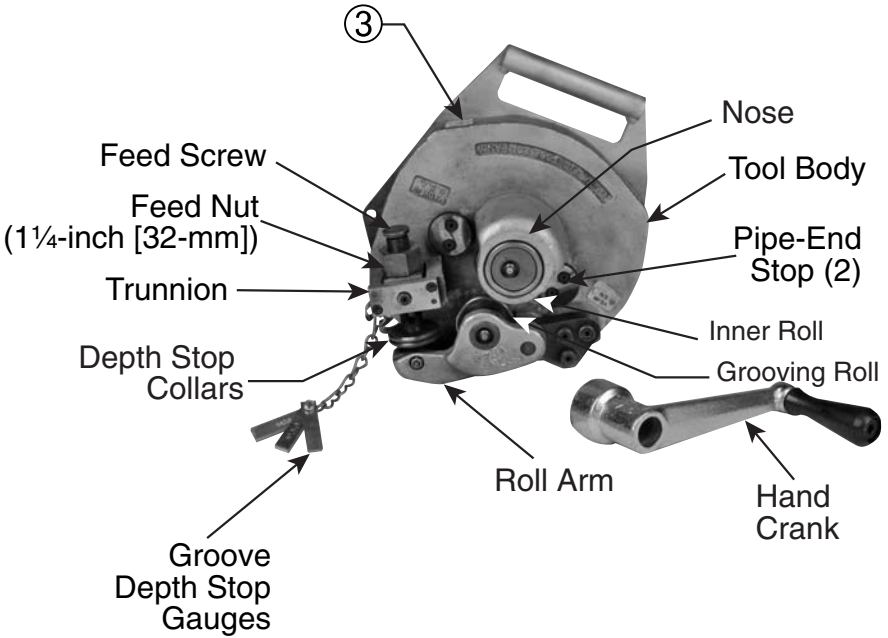

## OPPOSITE SIDE OF TOOL

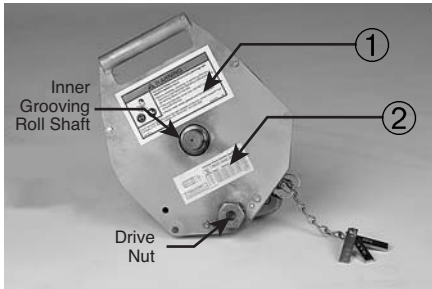

- ② Groove Diameter "C" Dimension Label (Varies depending upon which tool configuration is ordered)

③

**KEEP  
HANDS  
AWAY**

- ① Warning Label (Varies depending upon which tool configuration is ordered)

## TOOL SETUP

VE46 tools can be used to groove pipe that is supported by several different methods. Refer to the setup instructions listed in this section for different grooving options.

### PIPE VISE SETUP

**1.** When grooving pipe that is supported with a pipe vise, select a location for the tool and pipe vise by taking into consideration the following factors:

- 1a.** Adequate space to handle pipe lengths
- 1b.** A firm and level surface for the pipe vise
- 1c.** Anchoring requirements for the pipe vise
- 2.** Mount a chain-type pipe vise onto a stand or workbench. The pipe vise should be mounted flush with or slightly overhang the edge of the stand or workbench. When the tool is mounted on the pipe, the tool must be able to rotate freely around the pipe without being obstructed by the stand or workbench.



**3.** Secure a length of pipe in the pipe vise. Pipe position and pipe vise anchoring must be capable of handling the weight of the tool (tool weighs approximately 28 pounds [13 kilograms]), plus the manual effort required to operate the tool (approximately 20 ft-lbs [27 N•m] of torque). Position the pipe to overhang the pipe vise approximately 5 – 12 inches (125 – 300 mm), as shown, so that the tool can rotate freely.

## GROOVE-IN-PLACE SETUP

### ! WARNING



- Depressurize and drain the piping system before attempting to disassemble any Victaulic piping products.
- Pipe hangers must be capable of handling the weight of the tool and the manual effort required to operate the tool.

Failure to follow these instructions could result in serious personal injury and/or property damage.

Previously installed piping may be grooved with a VE46 tool, provided the piping is supported securely and that the system is completely depressurized and drained. Pipe hangers must be capable of handling the weight of the tool (tool weighs approximately 28 pounds [13 kilograms]), plus the manual effort required to operate the tool (approximately 20 ft-lbs [27 N•m]).

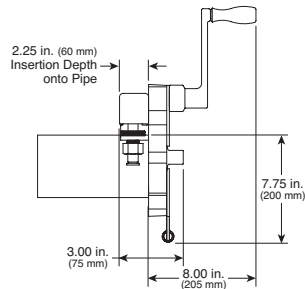
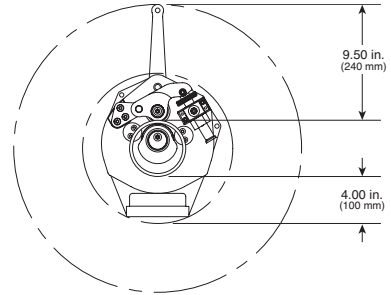

NOTE: These graphics show the VE46 mounted on a 4-inch diameter piece of pipe.

Make sure there is adequate clearance around the pipe to permit proper tool rotation during the grooving process. Refer to the drawings above for dimensions.

# POWER DRIVE MOUNTING PLATE KIT INSTALLATION

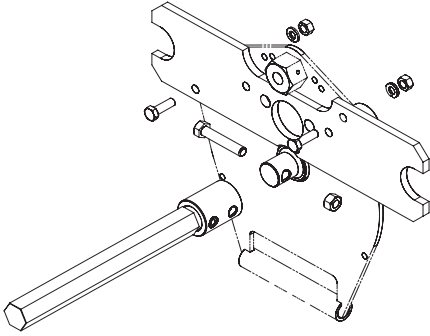

**1.** Install the drive shaft/drive-adaptor assembly onto the end of the lower shaft, as shown above. **NOTE:** Make sure the holes in the drive shaft/drive-adaptor assembly align with the holes in the inner grooving roll shaft.



**2.** Insert the hex-head bolt through the holes in drive shaft/drive-adaptor assembly and inner grooving roll shaft. Thread the hex nut with nylon insert onto the end of the hex-head bolt, as shown above.



**3.** Tighten the hex nut with nylon insert to secure the drive shaft/drive-adaptor assembly to the inner grooving roll shaft.



**4.** Install the power drive mounting plate onto the tool by placing the smaller cutout of the mounting plate toward the drive shaft/ drive-adapter assembly and the larger cutout toward the drive nut, as shown above.



**5.** Insert a hex-head cap screw into a hole in the mounting plate and tool body. Install a lock washer onto the end of the hex-head cap screw, and thread a hex nut onto the end of the hex-head cap screw. Repeat this procedure with the other hole in the mounting plate and tool body.

**5a.** Tighten the two hex nuts to secure the mounting plate to the tool body.

## POWER DRIVE SETUP

### WARNING

- **DO NOT** plug the power drive into the electrical source until instructed otherwise. Accidental startup of the tool could result in serious personal injury.

The VE46 tool is intended for field or shop set-up and can be attached to a Victaulic VPD752 Power Drive or a Ridgid 300 Power Drive with a 38-rpm maximum chuck speed. The power drive kit, which includes a special power drive mounting plate and hardware, must be ordered from the Victaulic Tool Company.

- 1.** Remove all components from the packaging, and make sure all necessary items are included. Refer to the "Receiving the Tool" section on page 5.
- 2.** Select a location for the power drive, tool, and pipe stand by taking into consideration the following factors (refer to the drawings below for overall dimensions):
  - 2a.** The required power supply (Refer to the power drive manufacturer's instructions)
  - 2b.** Adequate space to handle pipe lengths
  - 2c.** A firm and level surface for the power drive, tool, and pipe stand

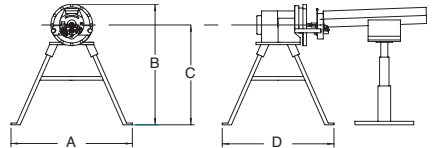

Dimensions – inches (millimeters)			
A	B	C	D
45.00 (1143,0)	43.00 (1092,2)	37.00 (939,8)	41.00 (1041,4)

- 2d.** Adequate clearance around the tool for adjustment and maintenance



- 3.** Make sure the hardware is tightened to secure the power drive to the power drive stand.

## NOTICE

- The cutoff attachments, threading dies, and reamer station do not need to be removed from the power drive. Refer to the photo shown below.



- 4.** Extend the two tubular support arms to their full extension beyond the chuck of the power drive.
- 4a.** Secure the two tubular support arms in position. Refer to the power drive manufacturer's instructions.



- 5.** Open the chuck of the power drive fully. Refer to the power drive manufacturer's instructions.
- 6.** Refer to the "Preparation for Grooving" section, starting on page 13, to install the power drive mounting plate onto the VE46 tool.



**7.** Orient the VE46 tool so that the roll arm is located in the 6 o'clock position. Align the flat portions of the drive shaft with the chuck jaws by turning the drive shaft. Install the tool assembly onto the power drive by inserting the drive shaft into the chuck and engaging the forks of the mounting plate with the tubular support arms of the power drive, as shown above. **NOTE:** The forks of the mounting plate should be approximately 4 inches (100 mm) back from the ends of the tubular support arms, as shown above.



**8.** Tighten the chuck. Make sure the chuck jaws engage with the flats of the drive shaft.

## **⚠ DANGER**



- To reduce the risk of electric shock, check the electrical source for proper grounding and follow all instructions.
- Before performing any maintenance on the tool, turn the switch on the power drive to the "OFF" position, or disconnect the power cord from the electrical source.

Failure to follow these instructions could result in death or serious personal injury.



**9.** Make sure the switch on the power drive is in the "OFF" position. Plug the power drive into an internally grounded electrical outlet. The outlet must meet the requirements for the

VE46 Pipe Roll Grooving Tool



power drive (refer to the power drive manufacturer's instructions). If an extension cord is used, refer to the "Extension Cord Requirements" section, starting on page 6, for requirements.

## **WARNING**

- The power drive **MUST** be operated with a safety foot switch. If the power drive does not contain a safety foot switch, contact the power drive manufacturer.

Operating the tool without a safety foot switch could result in serious personal injury.



**10.** Turn the power drive switch to the position that will produce **CLOCKWISE** rotation of the chuck when viewed from the front of the tool. On the Victaulic VPD752 or Ridgid 300 Power Drive, placing the switch in the **REVERSE** position will produce **clockwise** rotation of the chuck, lower roll, and pipe.

**11.** Depress the safety foot switch, check the rotation of the chuck and lower roll, and make sure the tool is stable. If rotation is **counter-clockwise**, place the switch on the power drive to the opposite position. If the tool wobbles, make sure the tool is mounted squarely in the chuck and that the tool is level on the floor. If the wobble persists, the power drive support arms are bent or the power drive is damaged. Have the power drive repaired if the wobble persists.

## **PREPARATION FOR GROOVING**

The VE46 tool design eliminates the need for roll changes. However, before attempting to operate the tool, make sure the correct tool is used for the pipe size and material being grooved. Refer to the "Tool Ratings" section on page 29 for details.

## **PIPE PREPARATION**

For proper tool operation and production of grooves that are within Victaulic specifications, the following guidelines must be followed.

- 1.** Victaulic recommends square-cut pipe for use with grooved-end pipe products. Square-cut pipe **MUST** be used with Victaulic FlushSeal<sup>®</sup> gaskets. Beveled-end pipe may be used, provided that the wall thickness is standard wall (ANSI B36.10) or less and that the bevel meets ANSI B16.25 (37 $\frac{1}{2}$ <sup>°</sup>) or ASTM A-53 (30<sup>°</sup>). **NOTE:** Roll grooving beveled-end pipe may result in unacceptable flare.
- 2.** Raised internal and external weld beads and seams must be ground flush with the pipe surface 2 inches (50 mm) back from the pipe ends.
- 3.** All coarse scale, dirt, and other foreign material must be removed from the interior and exterior surfaces of the pipe ends.

## **CAUTION**

- For maximum grooving roll life, remove foreign material and loose rust from the interior and exterior surfaces of the pipe ends. Rust is an abrasive material that will wear the surface of grooving rolls. Foreign material may interfere with or damage grooving rolls, resulting in distorted grooves and grooves that are out of Victaulic specifications.

## PIPE LENGTHS SUITABLE FOR GROOVING

(Applies only to tools installed on a power drive)

The VE46 roll grooving tool installed on a power drive is capable of grooving short pipe lengths without the use of a pipe stand. Refer to the "Short Pipe Lengths" section on this page.

Pipe lengths longer than those listed in Table 1 on the following page (and up to 20 feet/6 meters) must be supported with a pipe stand.

Pipe lengths from 20 feet (6 meters) up to double-random lengths (approximately 40 feet/12 meters) must be supported with two pipe stands.

### SHORT PIPE LENGTHS

 <b>WARNING</b>	
	<p><b>Grooving rolls can crush or cut fingers and hands.</b></p> <ul style="list-style-type: none"> <li>• Never groove pipe that is shorter than the recommended lengths listed in this manual.</li> </ul>

Table 1 shows the minimum and maximum pipe lengths that can be grooved without the use of a pipe stand. Refer to the "Grooving Operation For Power Drive Setup" section, starting on page 22, for instructions on how to groove short pipe lengths. For pipe longer than what is shown in Table 1, refer to the "Long Pipe Lengths" section on page 15.

<b>NOTICE</b>
<ul style="list-style-type: none"> <li>• Grooved pipe nipples, shorter than those listed in the following tables, are available from Victaulic.</li> </ul>

**TABLE 1 – PIPE LENGTHS SUITABLE FOR GROOVING**

Steel, Stainless Steel, Aluminum, and PVC Pipe		Length – inches (mm)	
Nominal Size inches or mm	Actual Outside Diameter inches (mm)	Minimum	Maximum
3 1/2	4.000 101,6	8 205	36 915
108,0 mm	4.250 108,0	8 205	36 915
4	4.500 114,3	8 205	36 915
4 1/2	5.000 127,0	8 205	32 815
133,0 mm	5.250 133,0	8 205	32 815
139,7 mm	5.500 139,7	8 205	32 815
5	5.563 141,3	8 205	32 815
152,4 mm	6.000 152,4	10 255	30 765
159,0 mm	6.250 159,0	10 255	30 765
165,1 mm	6.500 165,1	10 255	28 715
6	6.625 168,3	10 255	28 715

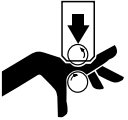
If pipe is required that is shorter than the minimum lengths listed in the above table, shorten the next-to-last piece so that the last piece is as long (or longer) than the minimum length specified. Refer to the example below.

**EXAMPLE:** A 20-foot, 4-inch (6,2-m) length of 6-inch diameter steel pipe is required to finish a section, and only 20-foot (6,1-m) lengths are available. Instead of roll grooving a 20-foot (6,1-m) length of steel pipe and a 4-inch (0,1-m) length of steel pipe, follow these steps:

1. Refer to Table 1 and note that for 6-inch diameter steel pipe, the minimum length that should be roll grooved is 10 inches (255 mm).
2. Roll groove a 10-foot, 6-inch (3,2-m) length of steel pipe and a 10-inch (255-mm) length of steel pipe. Refer to the "Long Pipe Lengths" section on page 15.



## LONG PIPE LENGTHS

When roll grooving pipe that exceeds the maximum length shown in Table 1, a roller-type pipe stand must be used. The roller-type pipe stand must be capable of handling the weight of the pipe, while allowing the pipe to rotate freely.

- a. Make sure the power drive and pipe stand are located on a firm and level surface.

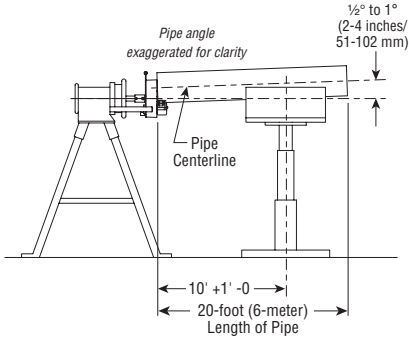

Figure 1 - Support of Pipe

- b. Place the pipe stand at a distance slightly beyond half the pipe length from the tool. Refer to Figure 1 above.

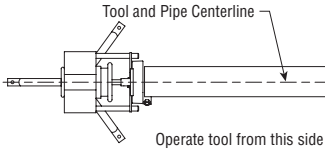

Figure 2 - Tracking Angle

- c. Position the centerline of the pipe stand along the centerline of the tool. Refer to Figure 2 above.

## NOTICE

- Pipe must be positioned ABOVE level when using VE46 and VE26 roll grooving tools with a power drive.
- All other Victaulic roll grooving tools require pipe positioning that is below level.

- d. Adjust the height of the pipe stand so that the pipe is approximately  $1/2^\circ$  to  $1^\circ$  ABOVE level. Refer to Figure 1 above. **NOTE:** The pipe must be inserted into the rolls while the height of the pipe stand is adjusted.

## ! CAUTION

- Make sure the pipe stand is positioned properly to prevent flaring of the pipe end.
- Always refer to the applicable "Roll Groove Specifications" table for details.

Installation of couplings on pipe that exceeds the maximum allowable flare may prevent pad-to-pad closure of the housings and/or may cause damage to the coupling gasket, resulting in property damage.

## NOTICE

- Figure 1 shows the Victaulic Adjustable Pipe Stand (VAPS 112). The VAPS 112 is suitable for  $3/4$  - 12-inch sizes. The Victaulic Model VAPS 224 is suitable for 2 - 24-inch sizes. Refer to the "Accessories" section on page 26.
- For additional information about pipe stands, refer to the instructions included with the pipe stand.

## GROOVE DEPTH ADJUSTMENT

The depth stop collars must be adjusted for each pipe size or change in wall thickness. The groove diameter, which is identified as the "C" dimension, is listed under the "Roll Groove Specifications" section, starting on page 31. In addition, a label is affixed to the tool, which lists the "C" dimensions for the pipe sizes.

### NOTICE

- To perform the following adjustments, use several short scrap sections of pipe that is the proper material, diameter, and thickness to be grooved. Make sure the scrap sections meet the length requirements listed in Table 1 on page 14.



1. Unlock and separate the depth stop collars by turning them in opposite directions.



2. Clamp the pipe in the tool by turning the feed nut clockwise. Continue to turn the feed nut clockwise until the grooving rolls make firm contact with the pipe.



3. Remove the groove depth gauges from the clip on the tool. The groove depth gauges are identified with the pipe size. Select the correct groove depth gauge, and place it between the depth stop collar and trunnion, as shown above.



**4.** Using the groove depth gauge like a feeler gauge, turn the depth stop collar until it contacts the groove depth gauge firmly against the top of the trunnion. Turn the second collar until it is locked firmly against the depth stop collar. Locking the two collars will maintain the gap set with the groove depth gauge.

**4a.** Remove the groove depth gauge from between the collar and trunnion. Place the groove depth gauges back into the clip provided on the tool.

**5.** Prepare a trial groove. Refer to the applicable "Grooving Operation" section, starting on page 18 or 22.



**6.** After a trial groove is prepared and the pipe is removed from the tool, carefully check the groove diameter ("C" dimension). Refer to the "Roll Groove Specifications" section, starting on page 31. The PT-100 Pipe Tape, supplied with the tool, is the best method for checking the "C" dimension. In addition, a vernier caliper or narrow-land micrometer can be used to check this dimension at two loca-

tions (90° apart) around the groove. The average reading must be within the required groove diameter specification.

### **CAUTION**

- The "C" dimension (groove diameter) must conform to Victaulic specifications to ensure proper joint performance.

**Failure to follow this instruction could cause joint failure, resulting in personal injury and/or property damage.**

**7.** If the groove diameter ("C" dimension) is not within Victaulic specifications, the depth stop collars must be adjusted.

**7a.** To adjust for a smaller groove diameter, turn the depth stop collars away from the trunnion.

**7b.** To adjust for a larger groove diameter, turn the depth stop collars toward the trunnion.

**NOTE:** A quarter-turn either way will change the groove diameter approximately 0.012 inch (0,3 mm) or 0.048 inch (1,2 mm) per full turn.

**8.** Prepare another trial groove, and check the groove diameter ("C" dimension), as described in steps 5 - 6 on this page. Repeat these steps, as necessary, until the groove diameter is within specification.

# GROOVING OPERATION

*For Pipe Vise Setup or Groove-In-Place Setup*

## CAUTION

- This tool must be used **ONLY** for roll grooving pipe designated in the "Tool Ratings" section of this manual.

Failure to follow this instruction could overload the tool, resulting in reduced tool life and/or damage to the tool.

**1.** Make sure the proper tool is selected for the pipe to be grooved. Refer to the "Tool Ratings" section on page 29 for details.

**2.** Before grooving, make sure all applicable instructions in the previous sections of this manual have been followed.



**3.** Retract the roll arm fully by turning the feed nut **counterclockwise**.



**4.** With the drive nut toward the bottom (down position), insert the nose of the tool body into the pipe end. Push the tool onto the pipe until the pipe end contacts the two pipe-end stops.



**5.** Draw the rolls together by turning the feed nut **clockwise**. Continue to turn the feed nut **clockwise** until the grooving rolls make firm contact with the pipe.

## CAUTION

- **DO NOT** exceed the feed rates listed in this section.
- **Over-tightening (over-feeding)** will result in shortened bearing life and other tool damage.
- **Over-tightening and under-tightening** could result in the tool "walking" off the pipe.

Failure to follow these instructions could cause personal injury and/or tool damage.

**6.** Set the groove depth by referring to the "Groove Depth Adjustment" section, starting on page 16.



**7.** Advance the grooving roll by turning the feed nut **clockwise**. Refer to the "VE46 Feed Rates" table on this page. **NOTE:** Feed rates for VE46 tools vary depending upon the pipe material and wall thickness. DO NOT exceed the feed rates listed in this table.

#### VE46 Feed Rates

Tools	Pipe Material	Wall Thickness inches (mm)	Recommended Amount of Turns of Feed Nut to Advance the Grooving Roll
VE46S	Steel and Stainless Steel	0.083 – 0.134 2,1 – 3,4	1/2 Turn
		0.135 – 0.280 3,4 – 7,1	1/4 Turn
VE46P	Aluminum	0.083 – 0.134 2,1 – 3,4	2/3 Turn
		0.135 – 0.280 3,4 – 7,1	1/3 Turn
VE46P	PVC Plastic	0.226 – 0.432 5,7 – 11,0	3/4 Turn



**8.** Place the hand crank onto the drive nut. Crank the drive nut either **clockwise** or **counterclockwise** until the tool travels one full turn around the pipe.

**NOTE:** A ratchet with a 1 1/4-inch (32-mm) socket (not supplied) may be used in place of the hand crank to operate the VE46 tool in low clearance conditions.



**9.** Advance the grooving roll by turning the feed nut **clockwise**. Refer to the table on this page for the recommended amount of turns of the feed nut.



**10.** Crank the tool another full turn around the pipe.



**12.** Crank the tool one to three additional full turns around the pipe to ensure groove completion.



**11.** Continue grooving by advancing the feed and cranking the tool around the pipe until the depth stop collar contacts the trunion. At this point, the grooving roll cannot be advanced any further.

## DISMOUNTING THE TOOL

### CAUTION

- Always support the tool while retracting the grooving roll. Retracting the grooving roll loosens the tool from the pipe.

Failure to follow these instructions could cause the tool to fall, resulting in personal injury and/or tool damage.



1. Crank the tool until the drive nut is located in the down position.

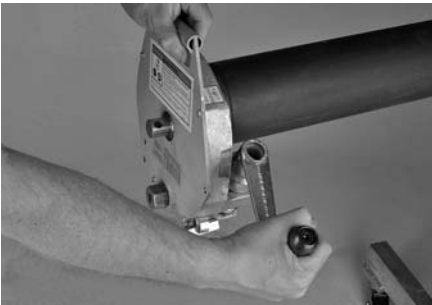

2. While supporting the tool, retract the grooving roll and arm to the fully open position by turning the feed nut **counterclockwise**.



3. Remove the tool from the pipe.

### NOTICE

- The groove diameter must be within specification for the diameter and wall thickness of pipe. The groove diameter should be checked and adjusted, as necessary, to ensure grooves remain within specification. Refer to steps 5 – 6 of the “Groove Depth Adjustment” section on page 17.

# GROOVING OPERATION

For Power Drive Setup

## ⚠ CAUTION

- This tool must be used **ONLY** for roll grooving pipe designated in the "Tool Ratings" section of this manual.

Failure to follow this instruction could overload the tool, resulting in reduced tool life and/or damage to the tool.

## ⚠ DANGER



- To reduce the risk of electric shock, check the electrical source for proper grounding and follow all instructions.
- Before operating the tool, review the "Operator Safety Instructions" section on page 3 of this manual.

Failure to follow these instructions could result in death or serious personal injury.

1. Make sure the proper tool is selected for the pipe to be grooved. Refer to the "Tool Ratings" section on page 29 for details.
2. Before grooving, make sure all applicable instructions in the previous sections of this manual have been followed.
3. Plug the power drive into an internally grounded electrical source. **NOTE:** The power drive **MUST** be grounded. Refer to the power drive manufacturer's instructions for detailed information.



4. Set the power drive switch to produce **CLOCKWISE** rotation of the VE46 inner roll and pipe when viewed from the front of the tool. On the Victaulic VPD752 Power Drive or the Ridgid 300 Power Drive, place the switch in the **REVERSE** position to produce **clockwise** rotation of the inner roll and pipe.

## ⚠ WARNING

- The power drive **MUST** be operated with a safety foot switch. If the power drive does not contain a safety foot switch, contact the power drive manufacturer.

Operating the tool without a safety foot switch could result in serious personal injury.

5. Make sure the tool is operational by depressing the safety foot-switch pedal. The inner roll must turn **CLOCKWISE** when viewed from the front of the tool. Remove foot from the safety foot switch.



## ! WARNING

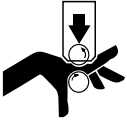

Grooving rolls can crush or cut fingers and hands.

- Before making any tool adjustments, always turn the switch on the power drive to the "OFF" position, or disconnect the power cord from the electrical source.

- Loading and unloading pipe will place your hands close to the rollers. Keep hands away from the grooving rolls during operation.
- Never reach inside pipe end or across the tool or pipe during operation.
- Always groove pipe in a **CLOCKWISE** direction only.
- Never groove pipe that is shorter than the recommended lengths listed in this manual.
- Never wear loose clothing, loose gloves, or anything else that can become entangled in moving parts.

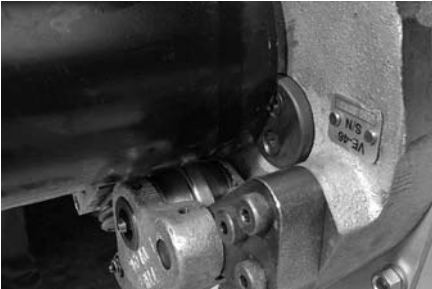

- 6.** Insert a length of pipe that is the correct size and thickness onto the lower roll. Make sure the pipe end contacts the two pipe-end stops completely.



- 7.** Draw the rolls together by turning the feed nut **clockwise**. Continue to turn the feed nut **clockwise** until the grooving rolls make firm contact with the pipe.

- 7a.** Remove hands from the pipe.

## ! CAUTION

- **DO NOT** exceed the feed rates listed in this section.
- **Over-tightening (over-feeding)** will result in shortened bearing life and other tool damage.
- **Over-tightening and under-tightening** could result in the tool "walking" off the pipe.

Failure to follow these instructions could cause personal injury and/or tool damage.



- 8.** Advance the grooving roll by turning the feed nut **clockwise**. Refer to the "VE46 Feed Rates" table below. **NOTE:** Feed rates for VE46 tools vary depending upon the pipe material and wall thickness. **DO NOT** exceed the feed rates listed in this table.

### VE46 Feed Rates

Tools	Pipe Material	Wall Thickness inches (mm)	Recommended Amount of Turns of Feed Nut to Advance the Grooving Roll
VE46S	Steel and Stainless Steel	0.083 – 0.134 2,1 – 3,4	1/2 Turn
		0.135 – 0.280 3,4 – 7,1	1/4 Turn
VE46P	Aluminum	0.083 – 0.134 2,1 – 3,4	2/3 Turn
		0.135 – 0.280 3,4 – 7,1	1/3 Turn
VE46P	PVC Plastic	0.226 – 0.432 5,7 – 11,0	3/4 Turn

- 9.** Set the groove depth by referring to the "Groove Depth Adjustment" section, starting on page 16.



**10.** Depress and hold down the safety foot-switch pedal. The pipe will begin to rotate **clockwise**. As the pipe rotates, begin the grooving process. Using the hand crank supplied with the tool, advance the grooving roll by turning the feed nut **clockwise**. Refer to the “VE46 Feed Rates” table for the recommended amount of turns of the feed nut.

**NOTE:** A ratchet with a 1 $\frac{1}{4}$ -inch (32-mm) socket (not supplied) may be used in place of the hand crank.



**11.** Continue grooving by turning the feed nut to advance the grooving roll until the depth stop collar contacts the trunnion. At this point, the feed nut cannot be advanced any further.

**12.** Continue pipe rotation for one to three additional revolutions to ensure groove completion.

**13.** Release the safety foot-switch pedal, and withdraw foot from the safety foot switch.

**14.** If a short length of pipe is in the tool, manually support the pipe.



**15.** To release the pipe, turn the feed nut **counterclockwise** to retract the roll arm to the fully open position. Slide the pipe out of the tool.

## NOTICE

- The groove diameter must be within specification for the diameter and wall thickness of pipe. The groove diameter should be checked and adjusted, as necessary, to ensure grooves remain within specification.

## WARNING

- **DO NOT** place hands inside the pipe end or in the area of the grooving rolls while the pipe is still rotating.

Failure to follow this instruction could result in serious personal injury.

## MAINTENANCE

---

### **⚠ DANGER**



- Before performing any maintenance on a tool installed on a power drive, turn the switch on the power drive to the “OFF” position, or disconnect the power cord from the electrical source.

Failure to follow this instruction could result in death or serious personal injury.

This section provides information about keeping tools in proper operating condition and guidance for making repairs when it becomes necessary. Preventive maintenance during operation will pay for itself in repair and operating savings.

Replacement parts must be ordered from Victaulic Tool Company to ensure proper and safe operation of the tool.

### **LUBRICATION**

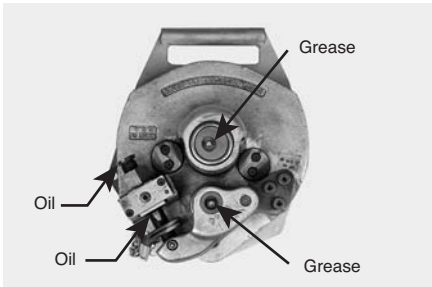

- 1.** After every 8 hours of operation, grease the bearings at the two grease fittings on the tool with a No. 2EP lithium-base grease.
- 2.** On a weekly basis, apply a light oil (SAE 10W-30 or equivalent) to the threads where the feed screw passes through the feed nut. Apply oil to the feed screw and trunnion pivots.

## PARTS ORDERING INFORMATION

---

When ordering parts, the following information is required for the Victaulic Tool Company to process the order and send the correct part(s). Request the RP-46 Repair Parts List for detailed drawings and parts listings.

1. Tool Model Number – VE46
2. Tool Serial Number – The serial number is stamped onto the tool body
3. Quantity, Part Number, and Description – For example, (1), R009046MCH, Feed Screw
4. Where to Send the Part(s) – Company name and address
5. To Whose Attention to Send the Part(s)
6. Purchase Order Number

Order parts from the Victaulic Tool Company at the address listed in this manual.

## ACCESSORIES

---

### VAPS 112 VICTAULIC ADJUSTABLE PIPE STAND



The Victaulic VAPS 112 is a portable, adjustable, roller-type pipe stand that contains four legs for additional stability. Ball transfer rollers, adjustable for  $\frac{3}{4}$  - 12-inch pipe, accommodate linear and rotational movement. The turnstile design permits ease of grooving for both pipe ends. Contact Victaulic Tool Company for details.

### VAPS 224 VICTAULIC ADJUSTABLE PIPE STAND

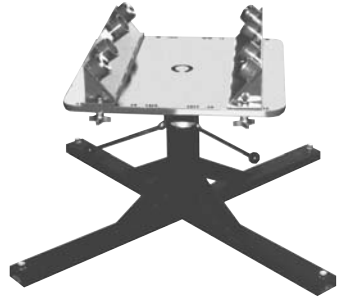

The Victaulic VAPS 224 contains features that are similar to the VAPS 112, but it is suitable for 2 – 24-inch pipe sizes. Contact the Victaulic Tool Company for details.

### VPD752 POWER DRIVE



The Victaulic VPD752 Power Drive can be used as the power drive unit for several different roll grooving tool models with the correct base plate. The power drive utilizes a 60 Hz universal motor and requires 115V/1 Phase, 15 amps of power. A safety foot switch is included for proper operation. Contact the Victaulic Tool Company for details.

# TROUBLESHOOTING

## GENERAL AND “IN-PLACE” GROOVING

Problem	Possible Cause	Solution
Unable to close rolls on pipe.	Improper adjustment of the depth stop collars.	Turn the depth stop collars away from the trunnion, and reset the depth stop collar. Refer to the "Groove Depth Adjustment" section on page 16.
Tool does not move when cranked.	Rust or dirt buildup is present on the roll set. Worn roll set.	Remove rust or dirt buildup from the roll set with a stiff wire brush. Inspect the roll set for worn knurls. Replace the roll set if excessive wear is present.
Tool wobbles during cranking.	Variation in pipe wall thickness or inadequate feed rate.	Advance the feed at the rate specified in the "Grooving Operation" section.
Tool will not track (tool "walks" or falls off pipe).	Tool is not correctly positioned on the pipe. Pipe end is not cut square. Improper feed rate.	Re-position the tool in the pipe against the two pipe-end stops. Cut the pipe square. Refer to the "Pipe Preparation" section on page 13. Advance the feed at the rate specified in the "Grooving Operation" section.
The tool will not groove the pipe.	Pipe is beyond the wall thickness capacity of the tool. Pipe material is excessively hard.	Refer to the "Tool Ratings" section on page 29. Refer to the "Tool Ratings" section on page 29.
Pipe grooves do not meet Victaulic specifications.	Depth stop collars are not adjusted correctly. Pipe is beyond the wall thickness capacity of the tool.	Refer to the "Groove Depth Adjustment" section on page 16. Refer to the "Tool Ratings" section on page 29.
Groove is too deep (groove diameter is too small).	Improper adjustment of the depth stop collars.	Reset the depth stop collars by referring to the "Groove Depth Adjustment" section on page 16.
Groove is too shallow (groove diameter too large).	Improper adjustment of the depth stop collars.	Reset the depth stop collars by referring to the "Groove Depth Adjustment" section on page 16.
The "A" Gasket Seat or "B" Groove Width dimensions do not meet Victaulic specifications.	Incorrect tool was selected for the pipe material.	Select the correct tool by referring to the "Tool Ratings" section on page 29.

Troubleshooting section continued on next page

## TOOLS INSTALLED ON A POWER DRIVE

Problem	Possible Cause	Solution
Pipe will not stay in the grooving rolls.	<p>Incorrect pipe positioning of long pipe length.</p> <p>Roll set and pipe are not rotating <b>clockwise</b>.</p>	<p>Refer to the "Long Pipe Lengths" section on page 15.</p> <p>Flip the switch on the power drive to the opposite rotation position.</p>
Pipe stops rotating during grooving.	<p>Rust or dirt buildup is present on the roll set.</p> <p>Rust or dirt is excessively heavy inside the pipe end.</p> <p>Worn roll set.</p> <p>Power drive has stalled due to over-advancing the grooving roll.</p> <p>The circuit breaker has tripped or a fuse has blown out on the electrical circuit that supplies the power drive.</p>	<p>Remove rust or dirt accumulation from the roll set with a stiff wire brush.</p> <p>Remove heavy rust and dirt from inside the pipe end.</p> <p>Inspect the roll set for worn knurls. Replace the roll set if excessive wear is present.</p> <p>Make sure the pipe is supported. Release the pipe by turning the feed nut <b>counterclockwise</b>, which will retract the roll arm and grooving roll to the fully open position. Refer to the "Grooving Operation For Power Drive Setup" section on page 22 to start the grooving process again.</p> <p>Reset the breaker, or replace the fuse.</p>
While grooving, loud squeaks echo through the pipe.	<p>Incorrect pipe support positioning on long pipe. Pipe is "over-tracking."</p> <p>Pipe is not cut square.</p> <p>Pipe is rubbing excessively on the two pipe-end stops.</p>	<p>Re-position the pipe/ support. Refer to the "Long Pipe Lengths" section on page 15.</p> <p>Cut the pipe end squarely.</p> <p>Remove the pipe from the tool, and apply a light coating of grease to the two pipe-end stops, as needed.</p>
During grooving, loud thumps or bangs occur approximately once every revolution of the pipe.	<p>Pipe has a pronounced weld seam.</p>	<p>Grind the raised welds flush with the interior and exterior pipe surfaces 2 inches (50 mm) back from the pipe end.</p>
Pipe flare is excessive.	<p>Pipe support is not adjusted properly for a long length of pipe.</p> <p>Tool is tilted backward while grooving a long length of pipe.</p> <p>Incorrect pipe support positioning of a long length of pipe. Pipe is "over-tracking."</p>	<p>Refer to the "Long Pipe Lengths" section on page 15.</p> <p>Refer to the "Long Pipe Lengths" section on page 15.</p> <p>Re-position the pipe support. Refer to the "Long Pipe Lengths" section on page 15.</p>

## TOOL RATINGS

### VE46S FOR STEEL AND SCHEDULE 40 STAINLESS STEEL PIPE VE46P FOR ALUMINUM AND PVC PIPE

Pipe Size		Nominal Wall Thickness Dimensions – inches (millimeters) *							
Nominal Size inches	Actual Outside Diameter inches (mm)	VE46S				VE46P			
		Steel Pipe Wall Thickness (Schedules 5, 10, and 40)		Stainless Steel Pipe Wall Thickness (Schedule 40)		Aluminum Pipe Wall Thickness (Schedule 40)		PVC Pipe Wall Thickness (Schedules 40 and 80) ‡	
		Min.	Max.	Min.	Max.	Min.	Max.	Min.	Max.
3 <sup>1</sup> / <sub>2</sub>	4.000 101,6	0.083 2,1	0.226 5,7	0.226 5,7	0.226 5,7	0.083 2,1	0.226 5,7	0.226 5,7	0.226 5,7
4	4.500 114,3	0.083 2,1	0.237 6,0	0.237 6,0	0.237 6,0	0.083 2,1	0.237 6,0	0.237 6,0	0.337 8,6
5	5.563 141,3	0.109 2,8	0.258 6,6	0.258 6,6	0.258 6,6	0.109 2,8	0.258 6,6	0.258 6,6	0.375 9,5
6	6.625 168,3	0.109 2,8	0.280 7,1	0.280 7,1	0.280 7,1	0.109 2,8	0.280 7,1	0.280 7,1	0.432 11,0

**This tool rating table is applicable only to ANSI piping and is based upon the following material grades. Refer to the appropriate international standard for other systems.**

Steel – Brinell Hardness Number (BHN) of 180 BHN and less.

Stainless Steel – Types 304/304L and Types 316/316L

Aluminum – ASTM B-210, Grades 6061-T4 and 6063-T4

PVC Type I, Grade I (PVC 1120)

PVC Type I, Grade II (PVC 1220)

PVC Type II, Grade I (PVC 2116)

\* All minimum and maximum wall thicknesses are nominal

‡ Schedule 40 PVC pipe is the maximum wall thickness that can be grooved in the 3<sup>1</sup>/<sub>2</sub>-inch size

# EXPLANATION OF CRITICAL ROLL GROOVE DIMENSIONS

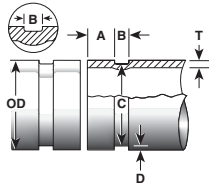

**Standard Roll Groove**

**Outside Diameter (“OD”) Dimension** – The outside diameter of roll grooved pipe must not vary from the specifications listed in the following tables. The maximum allowable tolerance from square-cut pipe ends is 0.030 inch (0,8 mm) for 3<sup>1</sup>/<sub>2</sub> - 6-inch sizes. This is measured from the true square line.

**“A” Dimension** – The “A” dimension, or the distance from the pipe end to the groove, identifies the gasket seating area. This area must be free from indentations, projections, and roll marks from the pipe end to the groove to provide a leak-tight seal for the gasket.

**“B” Dimension** – The “B” dimension, or groove width, controls expansion and angular deflection by the distance it is located from the pipe and its width in relation to the housings’ “key” width.

**“C” Dimension** – The “C” dimension is the proper diameter at the base of the groove. This dimension must be within the diameter’s tolerance and concentric with the OD for proper coupling fit. The groove must be of uniform depth for the entire pipe circumference.

**“D” Dimension** – The “D” dimension is the normal depth of the groove and is a reference for a “trial groove” only. Variations in pipe OD affect this dimension and must be altered, if necessary, to keep the “C” dimension within tolerance. This groove must conform to the “C” dimension.

**“F” Dimension (Standard Roll Groove Only)** – Maximum allowable pipe-end flare diameter is measured at the extreme pipe-end diameter.

**“T” Dimension** – The “T” dimension is the lightest grade (minimum, nominal wall thickness) of pipe that is suitable for roll grooving (except for PVC pipe).



# ROLL GROOVE SPECIFICATIONS

## VE46S FOR STEEL AND SCHEDULE 40 STAINLESS STEEL PIPE VE46P FOR ALUMINUM AND PVC PIPE

Nominal Size inches or mm	Pipe Size Actual OD Inches (mm)	Dimensions – inches (millimeters)																	
		Pipe Outside Diameter			Gasket Seat "A"			Groove Width "B"						Groove Diameter "C"			Groove Depth "D" (ref.)	Min. Allow. Wall Thick. "T" * 2.0	Max. Allow. Flare Dia. "F" 104.1
		Max.	Min.	Basic	Max.	Min.	Basic	Max.	Min.	Basic	Max.	Min.	Max.	Min.	Max.				
3 1/2	4.000 101.6	4.040 102.6	3.969 100.8	0.625 15.9	0.656 16.7	0.594 15.1	0.344 8.7	0.375 9.5	0.313 8.0	3.834 97.4	3.814 96.9	0.083 2.2	0.078 2.0	4.10 104.1					
108,0 mm	4.250 108.0	4.293 109.0	4.219 107.2	0.625 15.9	0.656 16.7	0.594 15.1	0.344 8.7	0.375 9.5	0.313 8.0	4.084 103.7	4.064 103.2	0.083 2.2	0.078 2.0	4.35 110.5					
4	4.500 114.3	4.545 115.4	4.469 113.5	0.625 15.9	0.656 16.7	0.594 15.1	0.344 8.7	0.375 9.5	0.313 8.0	4.334 110.1	4.314 109.6	0.083 2.2	0.078 2.0	4.60 116.8					
4 1/2	5.000 127.0	5.050 128.3	4.969 126.2	0.625 15.9	0.656 16.7	0.594 15.1	0.344 8.7	0.375 9.5	0.313 8.0	4.834 122.8	4.814 122.3	0.083 2.2	0.078 2.0	5.10 129.5					
133,0 mm	5.250 133.0	5.303 134.7	5.219 132.6	0.625 15.9	0.656 16.7	0.594 15.1	0.344 8.7	0.375 9.5	0.313 8.0	5.084 129.1	5.064 128.6	0.083 2.2	0.078 2.0	5.35 135.9					
139,7 mm	5.500 139.7	5.556 141.1	5.469 138.9	0.625 15.9	0.656 16.7	0.594 15.1	0.344 8.7	0.375 9.5	0.313 8.0	5.334 135.5	5.314 135.0	0.083 2.2	0.078 2.0	5.60 142.2					
5	5.563 141.3	5.619 142.7	5.532 140.5	0.625 15.9	0.656 16.7	0.594 15.1	0.344 8.7	0.375 9.5	0.313 8.0	5.395 137.0	5.373 136.5	0.084 2.2	0.078 2.0	5.66 143.8					
152,4 mm	6.000 152.4	6.056 153.8	5.969 151.6	0.625 15.9	0.656 16.7	0.594 15.1	0.344 8.7	0.375 9.5	0.313 8.0	5.830 148.1	5.808 147.5	0.085 2.2	0.078 2.0	6.10 154.9					
159,0 mm	6.250 159.0	6.313 160.4	6.219 158.0	0.625 15.9	0.656 16.7	0.594 15.1	0.344 8.7	0.375 9.5	0.313 8.0	6.032 153.2	6.002 152.5	0.109 2.8	0.109 2.8	6.35 161.3					
165,1 mm	6.500 165.1	6.563 166.7	6.469 164.3	0.625 15.9	0.656 16.7	0.594 15.1	0.344 8.7	0.375 9.5	0.313 8.0	6.330 160.8	6.308 160.2	0.085 2.2	0.078 2.0	6.60 167.6					
6	6.625 166.3	6.688 169.9	6.594 167.5	0.625 15.9	0.656 16.7	0.594 15.1	0.344 8.7	0.375 9.5	0.313 8.0	6.455 164.0	6.433 163.4	0.085 2.2	0.078 2.8	6.73 170.9					

\* Except for PVC and stainless steel pipe. Refer to the Tool Ratings table on page 29.

**Victaulic Tool Company****Tool Shipments:**

1326 Tatamy Road, Easton, PA 18045-7400

**Sales & Lease Payments:**

P.O. Box 8538-244, Phila., PA 19171-0244

## Victaulic Companies

**CUSTOMER CARE CENTER**

Phone: 1-800-PICK-VIC (1-800-742-5842)

FAX: 610/923-3090

e-mail: pickvic@victaulic.com

**VICTAULIC TOOL COMPANY**

P.O. Box 31 • Easton, PA 18044-0031

Phone: 610/559-3300 • Fax: 610/923-3090

e-mail: victools@victaulic.com

**WORLD HEADQUARTERS**

P.O. Box 31 • Easton, PA 18044-0031

4901 Kesslersville Road • Easton, PA 18040 USA

Phone: 610/559-3300 • Fax: 610/250-8817

**VICTAULIC CONSTRUCTION PIPING SERVICES DIV.**

1818 Vultee Street • Allentown, PA 18103

Phone: 610/559-3488 • Fax: 610/923-3170

e-mail: cps@victaulic.com

## Victaulic Around the World

**VICTAULIC COMPANY OF AMERICA**

P.O. Box 31 • Easton, PA 18044-0031

Phone: 610/559-3300 • Fax: 610/250-8817

e-mail: victaulic@victaulic.com

**VICTAULIC COMPANY OF CANADA**

123 Newkirk Road • Richmond Hill, ON L4C 3G5

Phone: 905/884-7444 • Fax: 905/884-9774

e-mail: viccanada@victaulic.com

**VICTAULIC AMERICA LATINA**

P.O. Box 31 • Easton, PA USA 18044-0031

4901 Kesslersville Road • Easton, PA USA 18040

Phone: 610/559-3300 • Fax: 610/559-3608

e-mail: vical@victaulic.com

**VICTAULIC EUROPE**

Prijkelstraat 36 • 9810 Nazareth, Belgium

Phone: 32-9-381-15-00 • Fax: 32-9-380-44-38

e-mail: viceuro@victaulic.be

**VICTAULIC ASIA-PACIFIC**

Room 707, No. 600 Min Sheng Road

Pudong, Shanghai 200135, China

Phone: 86-21-58855151 • Fax: 86-21-58851298

e-mail: vicap@victaulic.com

**www.victaulic.com**