

Protective solutions

Applications

The KS-150 and KS-150-K are used as gastight closing valves of air ducts in Civil Defence and military shelters and industrial facilities. Temet gastight closing valves are primarily designed to separate contaminated and toxic-free spaces and to control the airflow between them.

Specification

Manufacturer of KS-150 and KS-150-K gastight closing valve is Temet, Helsinki Finland.

The KS-150 and KS-150-K gastight closing valve comprises a light metal alloy body with neoprene gaskets installed between two counter flanges. The closing part is an aluminum alloy (KS-150) or stainless steel (KS-150-K) flap installed within the body on a spindle with bearings. The flap can be locked in any position. All parts are effectively corrosion proofed: the valve body epoxy powder coated, the flap made of stainless steel or epoxy powder coated and other components galvanized.

Design Criteria

The KS-150 and KS-150-K gastight closing valve is made in accordance with the specific provisions issued by the Finnish Ministry of Interior. The KS-150 and KS-150-K gastight closing valves also meet the requirements of the Swiss Federal Office of Civil Defence. The valve is also approved by the Norwegian Directorate for Civil Defence (DSB) to fulfil the Norwegian specifications for shelter equipment. The KS-150 and KS-150-K are type tested and approved for use by the Technical Research Centre of Finland / VTT Building Technology, an Independent Testing Authority mandated to perform type inspection for shelter equipment and systems by the Ministry of Interior. Type test reports as well as additional test data are available upon request. The fabrication, testing and inspection can be performed in accordance with the NATO AQAP-130 quality control procedures by the client's request.

The valve is designed to function within the operating temperature range of -20 ...+55°C.

Leakage rate

The leakage through the KS-150 and KS-150-K gastight closing valves does not exceed 2×10^{-4} l/s corresponding to a pressure differential of 1000 Pa across the valve. By pressurizing the void between the double flap of the KS-150-K valve with clean air, the leakage flow across the valve can be completely eliminated.

Type test report

VTT type test report available upon request

Other documents related to KS-150 and KS-150-K Gastight Closing Valves:

Installation Instructions

Maintenance Instructions

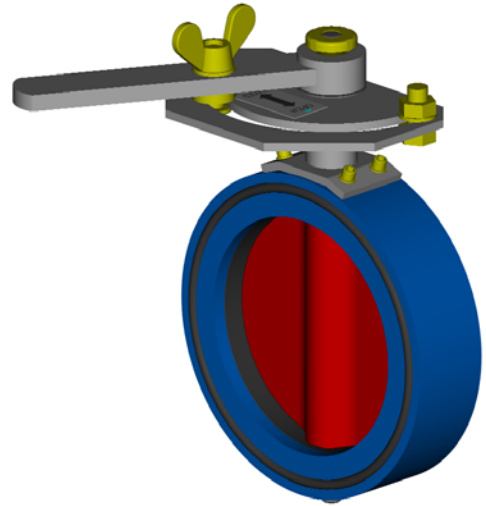

KS-150 Gastight Closing Valve

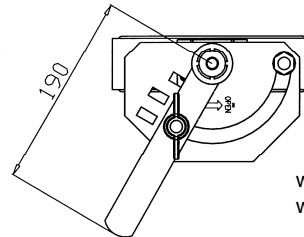
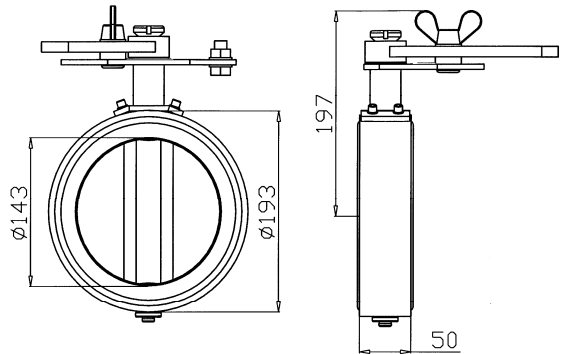

weight of valve 4.0 kg
weight of one counter flange 4.0 kg

KS-150 Gastight Closing Valve
dimensions

KS-150

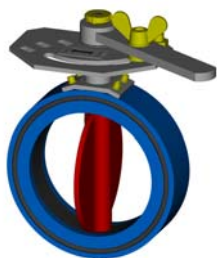

KS-150-K

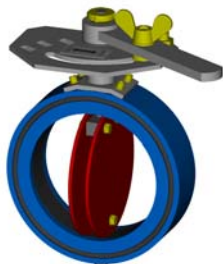

Accessories for KS valves:



KS valves are available provided with electric, electric fail-safe and pneumatic actuators.

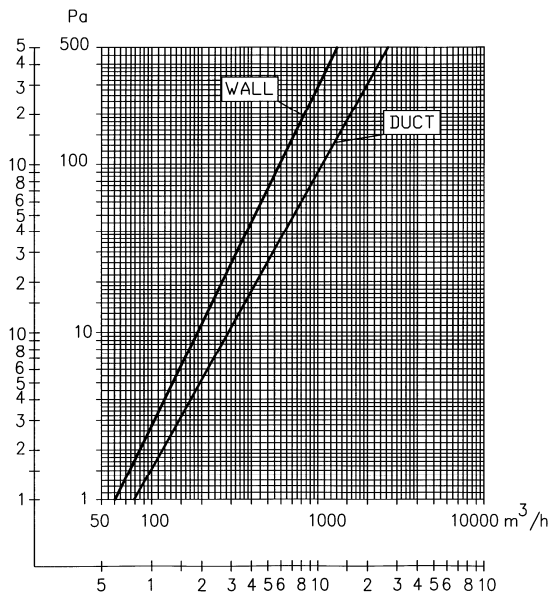

Air flow characteristics measured at 20 °C corresponding to air density of 1.2 kg/m³.

ALSO AVAILABLE

limit switches for the valve flap position indication

alternate materials for special applications

custom made wall sleeves etc.

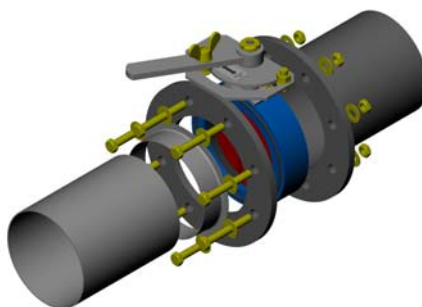
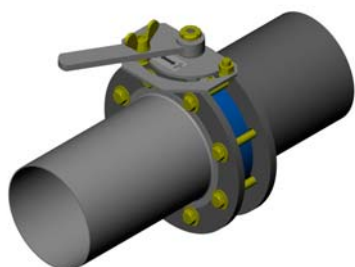

Typical Installations of KS valves

Valves can be installed between ducts, into flanged wall sleeves, etc. Detailed instructions for installation, maintenance and use are attached to every valve delivered.

Design - Production – Installation – Maintenance - Consultation