

Protective solutions

Applications

The VTV2G/35-50A and -50B ground shock isolators are used for shock mounting of equipment installations in hardened Civil Defence and military shelters. Temet ground shock isolators are primarily designed to protect mechanical and electrical installations against ground shock effects and to prevent transmittance and propagation of self-excited vibrations.

Specification

Manufacturer of VTV2G/35-50A and -50B ground shock isolators is Temet, Helsinki Finland.

The main components of the isolator spring unit are made of steel and coated by electroplating to ensure corrosion resistance. Support brackets and wall consoles are made of structural steel and treated either by hot dip galvanizing or epoxy powder coating.

Design Criteria

The VTV-2G/35-50A and -50B ground shock isolators are designed and fabricated in accordance with shock spectrum measured in hard bedrock where maximum quantities of motion are 35 mm for displacement, 1.5 m/s for velocity and 50 g for acceleration. The function of the shock isolator is based on substantially low basic natural frequency of the isolated unit achieved by mounting it on soft compression springs. This prevents shock forces from the support base from transmitting through the isolator system. The efficiency of the shock isolation depends on the frequency of the ground shock excitation but is always more than 90 percent for disturbing frequencies above 10 Hz. In practice, this means that the transmitted shock force is always limited below 2.0 g.

The VTV-2G/35-50A and -50B isolators are in compliance with the specific provisions issued by the Finnish Ministry of Interior. The VTV-2G/35-50A and -50B isolators are type tested and approved for use by the Technical Research Centre of Finland / VTT Building Technology, an Independent Testing Authority mandated to perform type inspection for shelter equipment and systems by the Finnish Ministry of Interior.

Type test report

VTT type test report available upon request.

Other documents related to VTV2G/35-50A and -50B ground shock isolators:

Installation Instructions

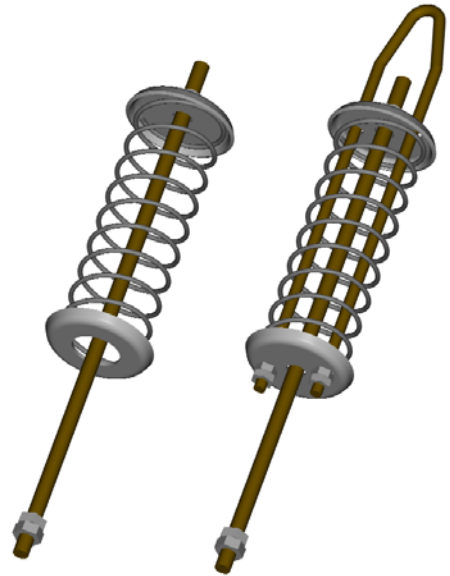

VTV2G/35-50A and 50B Ground Shock Isolators

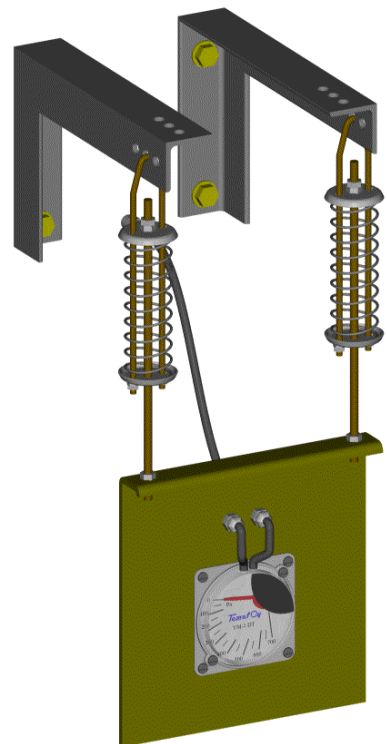

Example of shock isolation of light weight equipment using VTV2G/35-50B Ground Shock Isolators

The isolator type A or B is chosen on the basis of the desired method of suspension, type A for floor mount and type B for overhead mount. The size of the isolator and respective support bracket or console is selected on the basis of the pertinent static support reaction so that the load on each isolator must fall within the load range indicated in the type identification table below right.

The graph below shows the static load of each isolator as a function of the loaded spring height h . The graph is a great help for installation inspection in defining whether the selected isolators are of correct size. The installation inspection is performed by measuring the height of each isolator spring and comparing the result to the height range given in the graph. If the spring height falls out of the allowable range, the isolator and eventual support bracket or console must be replaced with a type of correct capacity.

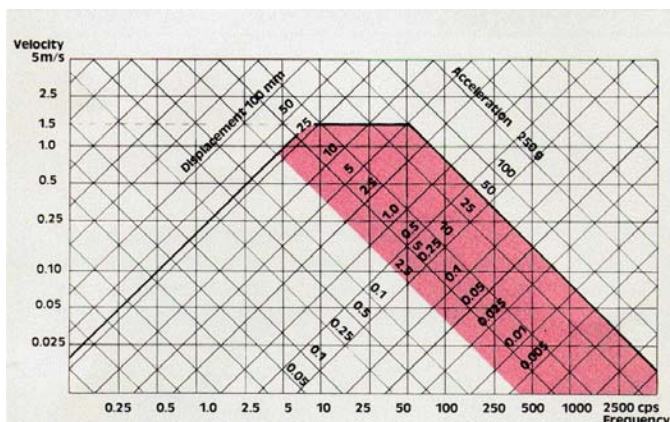
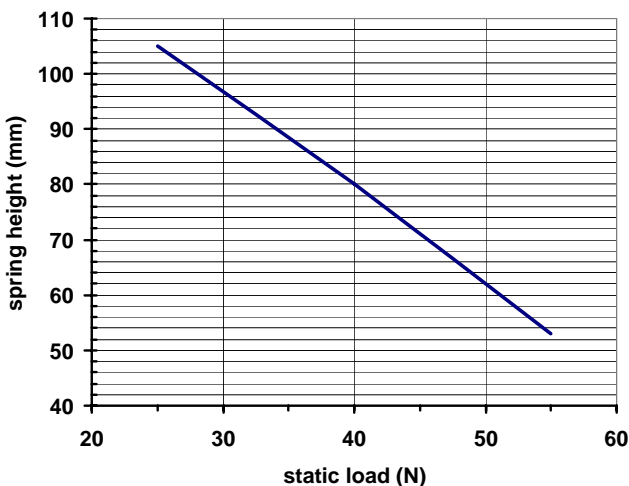

Shock spectrum indicating the envelopes for displacement, velocity and acceleration below which the VTV2G/35 shock isolator system is designed to operate. The practical shock isolation problems occur within the shaded area of the spectrum.

Support brackets and wall consoles

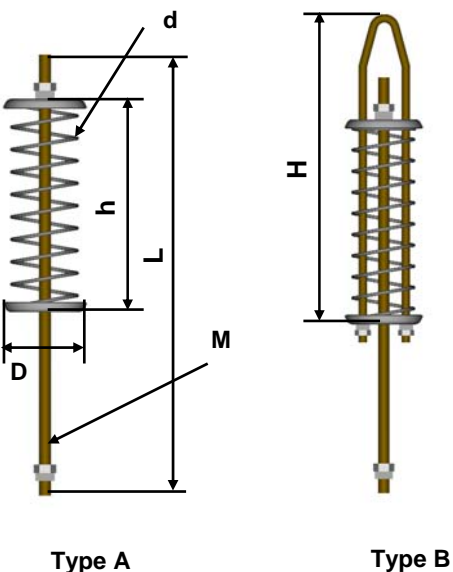
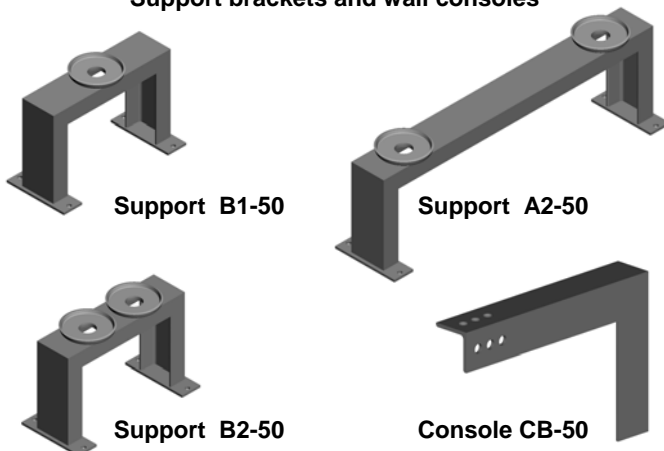

Temet VTV2G/35 shock isolator system is designed to operate within a wide load range due to the non-linear load-compression characteristics of the isolator spring. The isolator system comprises a series of 9 isolators with load ranges given in the table below as well as all necessary auxiliary components such as mounting brackets and wall consoles required for construction of complete shock isolation system. Additional design information is available from Temet.

VTV2G/35 type identification and dimensional data

Code	H	h	L	M	ØD	Ød	Min. Load N	Max. Load N
VTV2G/35-50	240-M6	145	300	8	55	2.5	20	50
VTV2G/35-100	240-M6	150	300	8	55	3.0	50	100
VTV2G/35-200	265-M8	170	350	10	90	5.0	100	200
VTV2G/35-400	265-M8	180	350	10	90	6.0	200	400
VTV2G/35-750	300-M10	207	400	12	115	7.0	350	750
VTV2G/35-1500	375-M12	240	450	12	135	11.0	750	1500
VTV2G/35-3000	375-M12	260	450	12	135	13.0	1500	3000
VTV2G/35-6000	470-M12	314	500	16	160	18.0	3000	6000
VTV2G/35-J			1035/770				20000	70000

Design - Production – Installation – Maintenance - Consultation