

Protective solutions

Applications

HV- Series Blast Dampers are designed for protection of ventilation systems against the effects of vapor and dust cloud explosions. The HV- Series Blast Dampers are applied in shielding of industrial facilities, such as O&G platforms and refineries or related buildings against destructive blast forces. The HV- series offers substantially higher air flow capacity and increased level of safety compared with other available products, as well as flexibility in design of duct systems.

Specification

Manufacturer of HV- Series Blast Dampers is Temet Oy, Helsinki Finland.

Structure of the HV- series damper is corrosion free, hot dip galvanized steel or AISI316 in the HV-SS version.

The HV- series damper has spring loaded closing blades built in a fully welded damper body to close the air passage in case of explosion or sudden increase of overpressure in the HVAC system. The threshold trigger pressure of the damper can be adjusted according customer specification.

Once closed the blades will remain in closed position until they are manually reset after the incident.

The HV- series dampers are approved according ATEX (Ex II 2 G D) for equipment in hazardous environment.

Main components

The HV- Series Blast Dampers comprise the following main components:

- Fully welded damper body made of 5mm steel
- Closing blades and shafts provided with stainless steel bearings
- Adjustable trigger mechanism
- Fragment grill
- Flow guides

Design Criteria

The HV- Series Blast Damper is designed for hazardous environment with a possibility of dust or vapor cloud explosion. Design criteria is a long duration pressure wave with finite rise time and 1.0 bar (14,5psi) peak overpressure.



Test and Performance Data

Performance of the HV- series Blast Damper is verified by tests in a large scale vapor cloud explosion simulator to effectively attenuate slowly rising (rise time = 100 ms) long duration (peak duration > 8000 ms) pressure wave loads within the load range up to 1.0bar. The damper is also tested to withstand the impact of high velocity flying objects according to ASTM E 1886 – 05 and 1996 – 05.

The damper is designed to function within the operating temperature range of -20...+200°C.

Test Reports

VTT Technical Research Center of Finland test report and additional test data is available upon request.

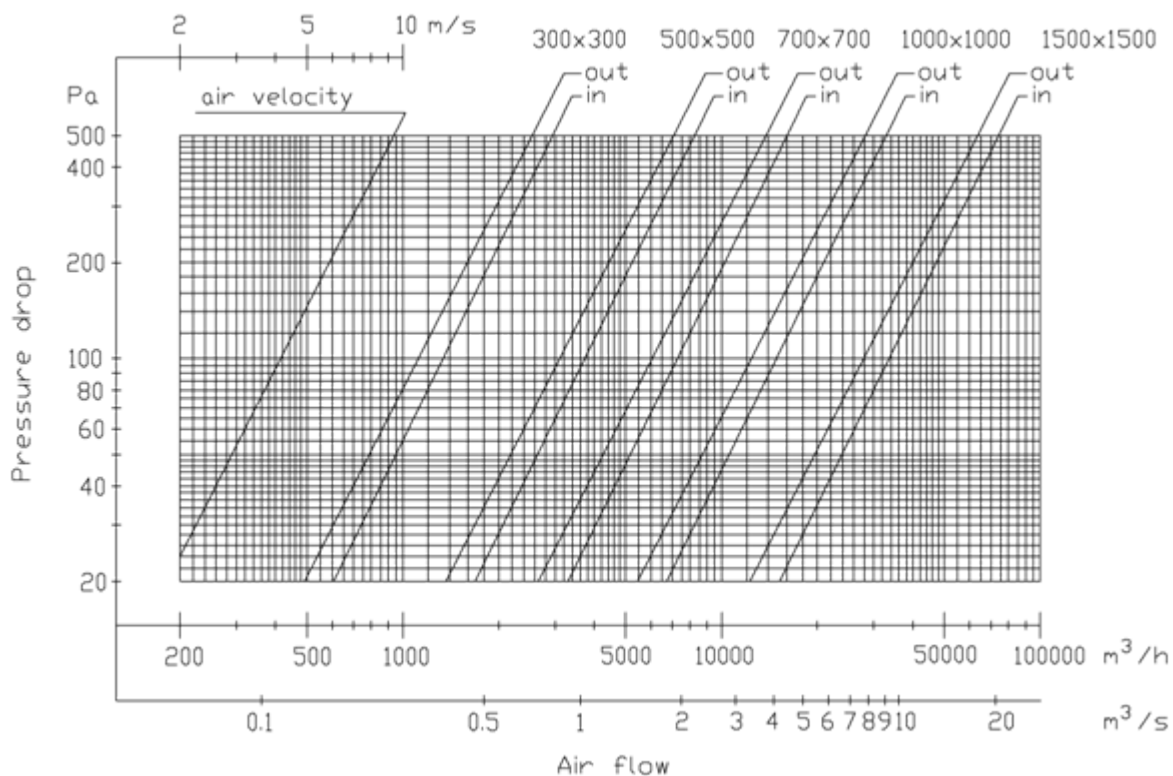

Air Flow Characteristics

Air flow characteristics of the standard size HV- Series Blast Dampers are given in the chart above. The flow curves are measured at 20 °C corresponding to air density of 1.2 kg/m³.

Design - Production – Installation – Maintenance - Consultation

Installation Alternatives

The HV- Series Blast Damper is designed to be installed onto the blast resistant wall or in the duct system.

The damper is installed on a concrete wall by means of anchor bolts. On a steel wall or duct the damper can be installed by bolting it with machine bolts.

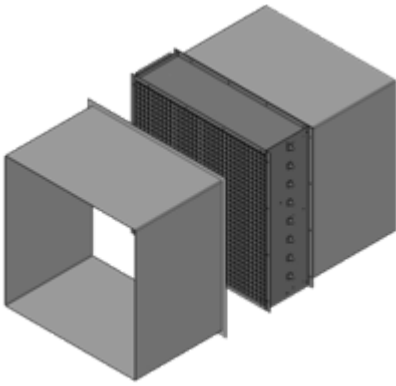

HV-Series damper installed in duct

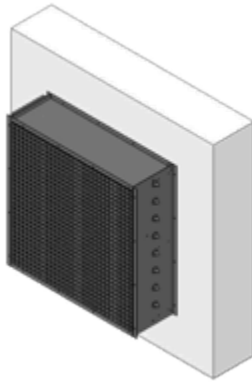

HV-Series damper installed onto blast resistant wall

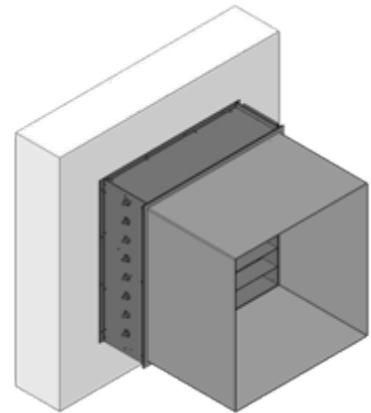

HV-Series damper installed inside of blast resistant wall and connected to duct

Product Coding

The HV- Series Blast Dampers are coded as follows:

Blast Damper HV-700x700 = damper width 700mm, damper height 700mm, material hot dip galvanized steel

Blast Damper HV-1500x1500-SS = damper width 1500mm, damper height 1500mm, material stainless steel AISI316.

Design - Production – Installation – Maintenance - Consultation

Dimensioning

The HV- Series Blast Dampers are dimensioned according to the duct size or wall opening. Standard sizes are 300mm x 300mm, 500mm x 500mm, 700mm x 700mm, 1000mm x 1000mm and 1500mm x 1500mm. The dampers are also available in custom sizes with steps of 100mm in each direction between the limits.

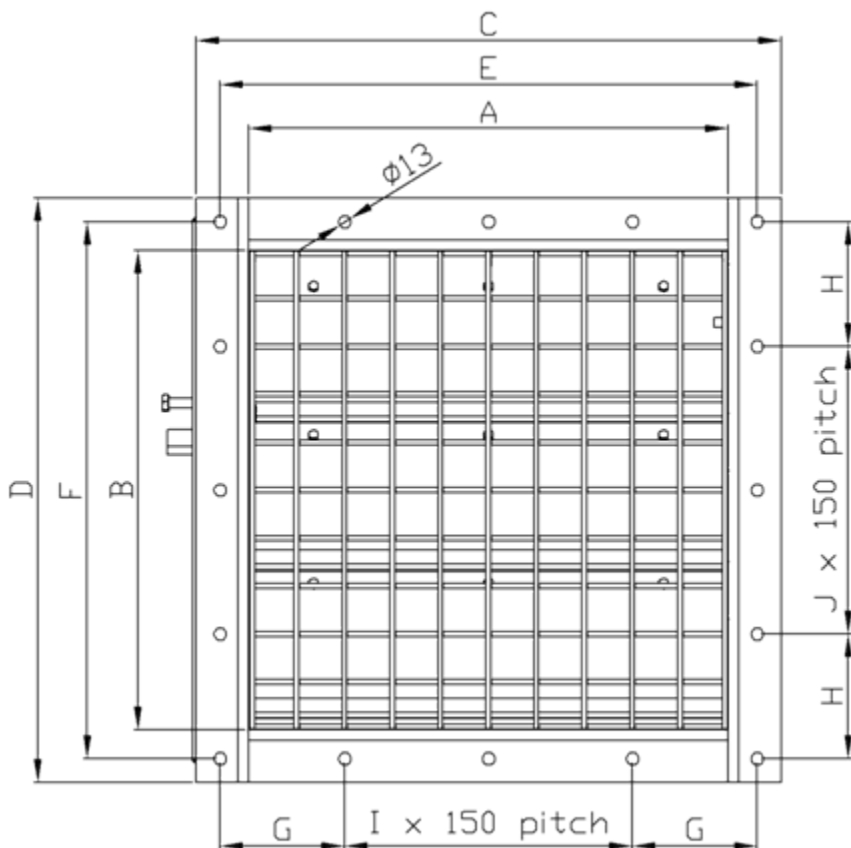

Damper type	Dimensions [mm]							
	A	B	C	D	E	F	G	H
HV-300x300	300	300	410	410	360	360	105	105
HV-500x500	500	500	610	610	560	560	130	130
HV-700x700	700	700	810	810	760	760	80	80
HV-1000x1000	1000	1000	1110	1110	1060	1060	80	80
HV-1500x1500	1500	1500	1610	1610	1560	1560	105	105

Note: G and H are greater than 75 mm but less or equal than 150 mm.

Design - Production – Installation – Maintenance - Consultation